

H1C

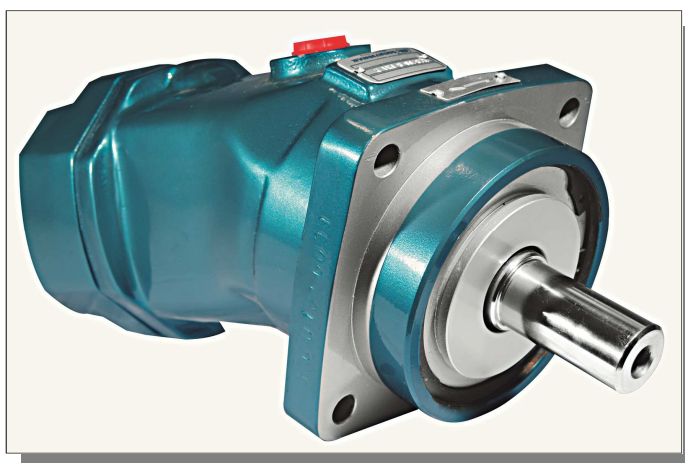

POMPE / MOTORI A CILINDRATA FISSA

FIXED DISPLACEMENT PUMPS / MOTORS

DESCRIZIONE - CARATTERISTICHE GENERAL INFORMATION - FEATURES

Le unità della serie H1C sono una famiglia di pompe e motori a pistoncini assiali, a corpo inclinato, a cilindrata fissa, progettati per operare sia in circuito chiuso che in circuito aperto. Il distributore a superficie sferica, l'accurata lavorazione e l'alta qualità dei materiali e dei componenti usati, consentono ai motori della serie H1C di lavorare fino a 350 bar in continuo e di sopportare picchi di 450 bar. Provatissimi in laboratorio e sperimentati sul campo queste unità hanno dimostrato una lunga durata di esercizio con elevati rendimenti. Il supporto dell'albero, realizzato mediante cuscinetti a rotolamento, è dimensionato in modo da sopportare elevati carichi assiali e radiali. La versatilità delle serie H1C, comprendente vari coperchi, alberi di uscita e valvole flangiabili, consente a queste unità di adattarsi alle più diverse tipologie di impianto, sia nel settore mobile che in quello industriale. Le unità a pistoncini H1C sono disponibili in versione ISO e in versione SAE.

H1C series units are a family of fixed displacement pumps and motors, bent axis piston design for operation in both open and closed circuit. The proven design incorporating the lens shape valve plate, the high quality components and manufacturing techniques make the H1C series units to able provide up to 350 bar [5100 psi] continuous and 450 bar [6500 psi] peak performance. Fully laboratory tested and field proven, these units provide maximum efficiency and longlife. Heavy duty bearings permit high radial and axial loads. Versatile design includes a variety of port plate, shaft end and valves package that will adapt the H1C series units to any application both industrial and mobile. H1C series units are available in both ISO and SAE version.

Fluidi:

Utilizzare fluidi a base minerale con additivi anticorrosione, antiossidanti e antiusura (HL o HM) con viscosità alla temperatura di esercizio di $15 \div 40$ cSt. Una viscosità limite di 800 cSt è ammissibile solo per brevi periodi in Condizione di partenza a freddo. Non sono ammesse viscosità inferiori ai 10 cSt. Viscosità comprese tra i 10 e i 15 cSt sono tollerate solo in casi eccezionali e per brevi periodi. Per maggiori dettagli consultare nel Catalogo Informazioni Generali la sezione "Fluidi e filtrazione".

Temperature:

Non è ammesso il funzionamento dell'unità a pistoni con temperature del fluido idraulico superiori a 90°C e inferiori a -25°C . Per maggiori dettagli consultare la sezione Fluidi e filtrazione.

Filtrazione:

Una corretta filtrazione contribuisce a prolungare la durata in esercizio dell'unità a pistoni. Per un corretto impiego dell'unità a pistoni la classe di contaminazione massima ammessa è 21/19/16 secondo la ISO 4406:1999. Per maggiori dettagli consultare nel Catalogo Informazioni Generali la sezione "Fluidi e filtrazione".

Pressione di alimentazione:

(Pompe in circuito aperto) La pressione minima sulla bocca di aspirazione e di 0.8 bar assoluti. La pressione sulla bocca di aspirazione non deve mai scendere al di sotto di tale valore.

Pressione di esercizio:

La pressione massima ammissibile sulle bocche in pressione è 350 bar continui e 450 bar di picco. Nel caso di due motori collegati in serie limitare la pressione di esercizio ai seguenti valori: P1 400 bar massimi e P2 200 bar massimi.

Pressione in carcassa:

La pressione massima ammissibile in carcassa è di 1.5 bar. Una pressione superiore può compromettere la durata e la funzionalità della guarnizione dell'albero di uscita.

Guarnizioni:

Le guarnizioni utilizzate sulle unità a pistoni assiali H1C standard sono in NBR (Acrylonitrile-Butadiene Elastomer). Per impieghi particolari (alte temperature e fluidi corrosivi) è possibile ordinare l'unità a pistoni con guarnizioni in FKM (Fluoroelastomer). Nel caso di impiego di fluidi speciali contattare la Brevini Fluid Power S.p.A.

Albero di uscita:

L'albero di uscita è in grado di sopportare sia carichi radiali sia assiali. Per i valori ammissibili dei carichi applicabili consultare nel Catalogo Informazioni Generali, la sezione "Durata dei cuscinetti delle unità a pistoni assiali".

Hydraulic fluids:

Use fluids with mineral oil basis and anticorrosive, antioxidant and wear preventing addition agents (HL or HM). Viscosity range at operating temperature must be of $15 \div 40$ cSt. For short periods and upon cold start, a max. viscosity of 800 cSt is allowed. Viscosities less than 10 cSt are not allowed. A viscosity range of $10 \div 15$ cSt is allowed for extreme operating conditions and for short periods only. For further information see on the General Information Catalogue, the section "Fluids and filtering".

Temperature ranges:

The operating temperature of the oil must be within $-25^{\circ}\text{C} \div 90^{\circ}\text{C}$ [$-13^{\circ}\text{F} \div 194^{\circ}\text{F}$]. The running of the axial piston unit with oil temperature higher than 90°C [194°F] or lower than -25°C [-13°F] is not allowed. For further information see at Fluids and filtering section.

Filtering:

A correct filtering is essential for long and satisfactory life of axial piston units. In order to ensure a correct functioning of the unit, the max. permissible contamination class is 21/19/16 according to ISO 4406:1999. For further details see on the General Information Catalogue, the section "Fluids and filtering".

Inlet pressure:

(Pumps in open circuit) Minimum absolute pressure at suction port is 0.8 bar [11.6 psi]. In no circumstances can inlet pressure be lower.

Operating pressure:

The maximum permissible pressure on pressure ports is 350 bar [5100 psi] continuous and 450 bar [6500 psi] peak. If two motors are connected in series, working pressure has to be limited to following values: P1 400 bar max. [5800 psi] and P2 200 bar max. [2900 psi].

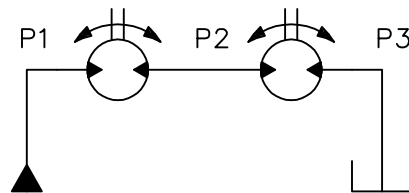

Case drain pressure:

Maximum permissible case drain pressure is 1.5 bar [22 psi]. A higher pressure can affect the main shaft seal or reduce its life.

Seals:

Seals used on standard H1C series axial piston pumps/motors are of NBR (Acrylonitrile-Butadiene Elastomer). For special uses (high temperatures or corrosive fluids) it is possible to order the unit with FKM seals (Fluoroelastomer). In case of use of special fluids, contact Brevini Fluid Power S.p.A.

Output shaft:

Main shaft has bearings that can bear both radial and axial loads. As for loads permissible values, see on the General Information Catalogue, the section "Service life of bearings for axial piston units".

Regime minimo di rotazione:

Con regime minimo di rotazione si intende la velocità minima alla quale l'unità a pistoni può ruotare in assenza di sensibili irregolarità di funzionamento. La regolarità di funzionamento a bassi regimi di rotazione è influenzata da numerosi fattori tra cui il tipo di carico applicato e la pressione di funzionamento. Per velocità di rotazione superiori ai 150 rpm la regolarità di funzionamento è assicurata quasi nella totalità dei casi. Velocità inferiori sono generalmente possibili. Per casi particolari contattare la Brevini Fluid Power S.p.A.

Installazione:

Le pompe e i motori possono essere installati in qualsiasi direzione e posizione. Queste unità a pistoni hanno le bocche separate dalla carcassa e devono essere obbligatoriamente drenate. Nel caso delle pompe l'installazione con albero verticale e al di sopra del serbatoio comporta alcune limitazioni. Per maggiori dettagli consultare nel Catalogo Informazioni Generali la sezione "Norme generali di installazione".

Valvole flangiabili:

Le valvole sono disponibili per i motori sia in circuito aperto sia chiuso. Per maggiori dettagli consultare il Catalogo Valvole.

Relazione tra senso di rotazione e direzione di flusso:

La relazione tra il senso di rotazione dell'albero dell'unità a pistoni H1C e la direzione del flusso del fluido è illustrata in figura.

Nota: nel caso di impiego come pompa è la posizione di montaggio del coperchio a determinare il senso di rotazione. Normalmente l'inversione del senso di rotazione di una pompa H1C comporta lo smontaggio del coperchio ed il suo rimontaggio ruotato di 180°.

Minimum rotating speed:

Minimum rotating speed is the minimum speed ensuring a smooth running of the piston unit. Operation smooth at low speeds depends on many factors, as type of load and operating pressure. At a speed higher than 150 rpm, a smooth running is ensured almost in every case. Lower speeds are, usually, possible. Please contact Brevini Fluid Power S.p.A.

Installation:

H1C series pumps and motors can be installed in every position or direction. These axial piston units have separate ports and drain chambers and so must be always drained. As for pumps, installation of the unit with shaft in vertical position and above the tank involves some limitations. For further details see on the General Information Catalogue, the section "General installation guidelines".

Flangeable valves:

Flangeable valves are available for motors both in open and closed loop. For further details see at Valves Catalogue.

Relation between direction of rotation and direction of flow:

The relation between direction of rotation of shaft and direction of flow in H1C piston units is shown in the picture below.

Note: for pump operation, the direction of rotation is determined by the port plate mounting position. Usually, in order to change direction of rotation of a pump, port plate has to be removed, turned of 180° and reassembled.

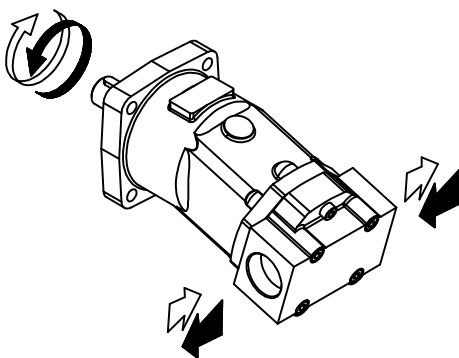

Motore reversibile
Reversible motor

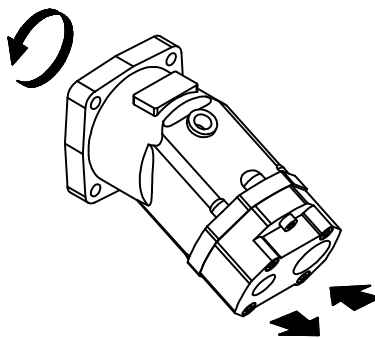

Pompa rotazione destra
CW rotating pump

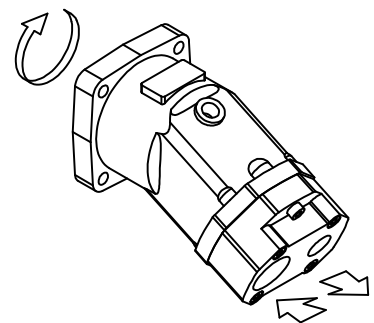

Pompa rotazione sinistra
CCW rotating pump

DATI TECNICI TECHNICAL DATA

Dimensione / Size				006	012	020	030	040	055
Cilindrata Displacement		V _g	cm ³ /rev [in ³ /rev]	6.067 [0.37]	10.9 [0.66]	19.6 [1.20]	30.0 [1.83]	40.1 [2.45]	54.8 [3.34]
Pressione max. Max. pressure	cont.	p _{nom}	bar [psi]	350 [5100]					
	picco peak	p _{max}	bar [psi]	450 [6500]					
* Velocità max. * Max. speed	motore motor	n _{0 max}	rpm	6000	5590	5590	4500	4350	3900
	pompa ⁽¹⁾ pump ⁽¹⁾	n _{1 max}	rpm	5000	4300	4300	3000	3300	2600
Portata max. Max. flow	motore motor	q _{max}	l/min [U.S. gpm]	36.4 [9.61]	61 [16.1]	109 [28.7]	135 [35.6]	175 [46.1]	214 [56.4]
	pompa ⁽²⁾ pump ⁽²⁾	q _{1 max}	l/min [U.S. gpm]	30.3 [7.99]	47 [12.4]	84 [22.2]	90 [23.7]	132 [34.8]	143 [37.7]
Potenza max. a p _{nom} Max. power at p _{nom}	motore motor	P _{max}	kW [hp]	21.2 [28.4]	35.5 [47.5]	64 [85.5]	79 [106]	102 [136.8]	125 [167.5]
	pompa ⁽²⁾ pump ⁽²⁾	P _{1 max}	kW [hp]	17.7 [23.7]	27 [36]	49 [65]	53 [71]	77 [103]	83 [111]
Costante di coppia Torque constant		T _k	Nm/bar [lbf-ft/psi]	0.097 [0.005]	0.17 [0.0087]	0.31 [0.016]	0.48 [0.024]	0.64 [0.032]	0.87 [0.044]
Coppia max. Max. torque	cont. (p _{nom})	T _{nom}	Nm [lbf-ft]	33.8 [24.9]	60.5 [44.5]	109 [80]	167 [123]	223 [164]	306 [225]
	picco peak (p _{max})	T _{max}	Nm [lbf-ft]	43.5 [32.1]	76 [56]	139 [102]	216 [159]	288 [212]	391 [288]
Momento di inerzia ⁽³⁾ Moment of inertia ⁽³⁾		J	kg·m ² [lbf-ft ²]	0.0007 [0.016]	0.0007 [0.016]	0.002 [0.047]	0.002 [0.047]	0.004 [0.094]	0.004 [0.094]
Peso ⁽³⁾ Weight ⁽³⁾		m	kg [lbs]	5.5 [12.1]	5.5 [12.1]	13 [28.7]	13 [28.7]	22 [48.5]	22 [48.5]
Portata di drenaggio ⁽⁴⁾ External drain flow ⁽⁴⁾		q _d	l/min [U.S. gpm]	0.4 [0.10]	0.4 [0.10]	0.4 [0.10]	0.6 [0.16]	0.7 [0.18]	0.8 [0.21]

(Valori teorici, senza considerare η_{hm} e η_v ; valori arrotondati). Le condizioni di picco non devono durare più dell'1% di ogni minuto. Evitare il funzionamento contemporaneo alla massima velocità e alla massima pressione.

* I valori relativi alle pompe si riferiscono all'impiego in circuito aperto.

(Theoretical values, without considering η_{hm} e η_v approximate values). Peak operations must not exceed 1% of every minute. A simultaneous maximum pressure and maximum speed not recommended.

* Pump values refer to open circuit operation.

Dimensione / Size				075	090	108	160	226
Cilindrata Displacement		V _g	cm ³ /rev [in ³ /rev]	75.3 [4.60]	87.0 [5.30]	107.5 [6.56]	160.8 [9.81]	225.1 [13.73]
Pressione max. Max. pressure	cont.	p _{nom}	bar [psi]	350 [5100]				
	picco peak	p _{max}	bar [psi]	450 [6500]				
* Velocità max. * Max. speed	motore motor	n _{0 max}	rpm	3450	3450	3000	2700	2400
	pompa ⁽¹⁾ pump ⁽¹⁾	n _{1 max}	rpm	2300	2500	2000	1800	1600
Portata max. Max. flow	motore motor	q _{max}	l/min [U.S. gpm]	259 [68.3]	300 [79.2]	322 [85]	434 [114.5]	540 [142.5]
	pompa ⁽²⁾ pump ⁽²⁾	q _{1 max}	l/min [U.S. gpm]	173 [45.6]	217 [57.3]	215 [56.7]	289 [76.3]	360 [95]
Potenza max. a p _{nom} Max. power at p _{nom}	motore motor	P _{max}	kW [hp]	151 [202.5]	175 [234.5]	188 [252]	253 [339]	315 [422]
	pompa ⁽²⁾ pump ⁽²⁾	P _{1 max}	kW [hp]	101 [135]	127 [170]	125 [167]	169 [226]	210 [281]
Costante di coppia Torque constant		T _k	Nm/bar [lbf-ft/psi]	1.20 [0.0061]	1.38 [0.070]	1.71 [0.087]	2.56 [0.130]	3.58 [0.182]
Coppia max. Max. torque	cont. (p _{nom})	T _{nom}	Nm [lbf-ft]	420 [310]	485 [357]	599 [442]	896 [661]	1254 [925]
	picco peak (p _{max})	T _{max}	Nm [lbf-ft]	540 [398]	623 [460]	770 [568]	1152 [849]	1613 [1189]
Momento di inerzia ⁽³⁾ Moment of inertia ⁽³⁾		J	kg·m ² [lbf-ft ²]	0.008 [0.190]	0.013 [0.308]	0.013 [0.308]	0.025 [0.593]	0.040 [0.949]
Peso ⁽³⁾ Weight ⁽³⁾		m	kg [lbs]	30 [66.1]	45 [99.2]	45 [99.2]	61 [134.5]	86 [189.6]
Portata di drenaggio ⁽⁴⁾ External drain flow ⁽⁴⁾		q _d	l/min [U.S. gpm]	0.9 [0.23]	1.0 [0.26]	1.2 [0.31]	1.8 [0.47]	2.5 [0.66]

(Valori teorici, senza considerare η_{hm} e η_v ; valori arrotondati). Le condizioni di picco non devono durare più dell'1% di ogni minuto. Evitare il funzionamento contemporaneo alla massima velocità e alla massima pressione.

* I valori relativi alle pompe si riferiscono all'impiego in circuito aperto.

Note: Determinazione della velocità ammissibile

⁽¹⁾ La velocità di rotazione della pompa può essere aumentata aumentando la pressione sulla bocca di aspirazione. La velocità di rotazione massima della pompa non deve superare in ogni caso il valore n_{0 max} indicato in tabella. Per la determinazione della velocità massima di rotazione ammissibile in funzione della pressione sulla bocca di aspirazione utilizzare il diagramma a lato. ⁽²⁾ Valori validi per un regime di rotazione pari ad n_{1 max}. ⁽³⁾ Valori indicativi. ⁽⁴⁾ Valori medi a 250 bar con olio minerale a 45°C e viscosità 35 cSt.

Notes: Calculation of permissible speed

⁽¹⁾ The pump rotation speed may be increased by increasing the suction pressure. The max. pump speed must be always less than value n_{0 max} shown in table. To calculate the max. permissible speed related to the pump suction pressure see the diagram at side. ⁽²⁾ The values are valid for a rotating speed of n_{1 max}. ⁽³⁾ Approximate values. ⁽⁴⁾ Average values at 250 bar [3600 psi] with mineral oil at 45°C [113°F] and 35 cSt of viscosity.

(Theoretical values, without considering η_{hm} e η_v approximate values). Peak operations must not exceed 1% of every minute. A simultaneous maximum pressure and maximum speed not recommended.

* Pump values refer to open circuit operation.

Determinazione della velocità limite / Speed limits calculation

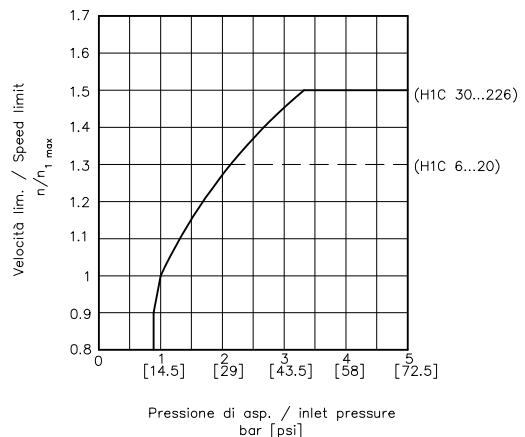

CODICE DI ORDINAZIONE ORDERING CODE

Le seguenti lettere o numeri del codice, sono state sviluppate per identificare tutte le configurazioni possibili della serie H1C. Usare il seguente modulo per identificare le caratteristiche desiderate. **Tutte le lettere o numeri del codice devono comparire in fase d'ordine.** Si consiglia di leggere attentamente il catalogo prima di iniziare la compilazione del codice di ordinazione.

The following alphanumeric codes system has been developed to identify all of the configuration options for the H1C series. Use the model code below to specify the desired features. **All alphanumeric digits system of the code must be present when ordering.** We advise to carefully read the catalogue before filling the ordering code.

CODICE PRODOTTO / MODEL CODE

1	2	3	4	5	6	7	8	9	10	10A	11	12	13

1 - SERIE / SERIES													
H1C	Unità a pistoni assiali, con corpo inclinato a cilindrata fissa Fixed displacement, bent axis, axial piston unit	•	•	•	•	•	•	•	•	•	•	•	•
2 - MOTORE-POMPA / MOTOR-PUMP													
M	Motore Motor	•	•	•	•	•	•	•	•	•	•	•	•
P	Pompa Pump	•	•	•	•	•	•	•	•	•	•	•	•
3 - CILINDRATA / DISPLACEMENT													
		006	012	020	030	040	055 ³⁾	075 ³⁾	090 ³⁾	108 ³⁾	160 ³⁾	226	
4 - VERSIONE / VERSION													
ME	ISO	•	•	•	•	•	•	•	•	•	•	•	•
SE	SAE			•	•	•	•	•	•	•	•	•	•
5 - FLANGIA / MOUNT FLANGE													
OA	ISO 4 fori Ø 80 mm ISO 4 Bolts Ø 80 mm [Ø 3.149 in]	ME	ME	/	/	/	/	/	/	/	/	/	/
OB	ISO 4 fori Ø 100 mm ISO 4 Bolts Ø 100 mm [Ø 3.937 in]	/	/	ME	ME	/	/	/	/	/	/	/	/
02	SAE-B 2 Fori SAE-B 2 Bolts	/	/	SE	SE	/	/	/	/	/	/	/	/
OC	ISO 4 fori Ø 125 mm ISO 4 Bolts Ø 125 mm [Ø 4.921 in]	/	/	/	/	ME	ME	/	/	/	/	/	/
05	SAE-C 4 Fori SAE-C 4 Bolts	/	/	/	/	SE	SE	/	/	/	/	/	/
OD	ISO 4 fori Ø 140 mm ISO 4 Bolts Ø 140 mm [Ø 5.511 in]	/	/	/	/	/	/	ME	/	/	/	/	/
08	SAE-D 4 Fori SAE-D 4 Bolts	/	/	/	/	/	/	SE	SE	SE	SE	SE	/
OE	ISO 4 fori Ø 160 mm ISO 4 Bolts Ø 160 mm [Ø 6.299 in]	/	/	/	/	/	/	/	ME	ME	/	/	/
OF	ISO 4 fori Ø 180 mm ISO 4 Bolts Ø 180 mm [Ø 7.086 in]	/	/	/	/	/	/	/	/	/	ME	/	/
OG	ISO 4 fori Ø 200 mm ISO 4 Bolts Ø 200 mm [Ø 7.874 in]	/	/	/	/	/	/	/	/	/	/	ME	ME
10	SAE-E 4 Fori SAE-E 4 Bolts	/	/	/	/	/	/	/	/	/	/	SE	SE

• Disponibile - Available / Non Disponibile - Not Available

- Il valore ME indica che la flangia è disponibile solo per la versione ISO
The ME code means that the flange is only available for the ISO version
- Il valore SE indica che la flangia è disponibile solo per la versione SAE
The SE code means that the flange is only available for the SAE version
- Fuori produzione
Out of production

1	2	3	4	5	6	7	8	9	10	10A	11	12	13

		006	012	020	030	040	055	075	090	108	160	226
6 - ESTREMITÀ ALBERO / SHAFT END												
CAV	Cilindrico Ø 20 mm k6 Parallel keyed Ø 20 mm k6 [0.787 in k6]	ME	ME	/	/	/	/	/	/	/	/	/
SAF	Scanalato W20x1.25x14x9g DIN 5480 Splined W20x1.25x14x9g DIN 5480	ME	ME	/	/	/	/	/	/	/	/	/
CBM	Cilindrico Ø 25 mm k6 Parallel keyed Ø 25 mm k6 [0.984 in k6]	/	/	ME-SE	ME-SE	/	/	/	/	/	/	/
SAG	Scanalato W25x1.25x18x9g DIN 5480 Splined W25x1.25x18x9g DIN 5480	/	/	ME-SE	ME-SE	/	/	/	/	/	/	/
C16	Cilindrico Ø 22.22 mm Parallel keyed Ø 22.22 mm [0.874 in]	/	/	SE	SE	/	/	/	/	/	/	/
S05	Scanalato Z13 16/32 DP Splined 13T 16/32 DP	/	/	SE	SE	/	/	/	/	/	/	/
CAW	Cilindrico Ø 30 mm k6 Parallel keyed Ø 30 mm k6 [1.181 in k6]	/	/	/	/	ME	ME	/	/	/	/	/
SAI	Scanalato W30x2x14x9g DIN 5480 Splined W30x2x14x9g DIN 5480	/	/	/	/	ME	ME	/	/	/	/	/
C17	Cilindrico Ø 31.75 mm Parallel keyed Ø 31.75 mm [1.25 in]	/	/	/	/	SE	SE	/	/	/	/	/
S12	Scanalato Z14 12/24 DP Splined 14T 12/24 DP	/	/	/	/	SE	SE	/	/	/	/	/
CAY	Cilindrico Ø 35 mm k6 Parallel keyed Ø 35 mm k6 [1.377 in k6]	/	/	/	/	/	/	ME	/	/	/	/
SAM	Scanalato W35x2x16x9g DIN 5480 Splined W35x2x16x9g DIN 5480	/	/	/	/	/	/	ME	/	/	/	/
SAO	Scanalato W40x2x18x9g DIN 5480 Splined W40x2x18x9g DIN 5480	/	/	/	/	/	/	ME	ME	ME	/	/
C18	Cilindrico Ø 44.45 mm Parallel keyed Ø 44.45 mm [1.75 in]	/	/	/	/	/	/	SE	SE	SE	SE	SE
S15	Scanalato Z13 8/16 DP Splined 13T 8/16 DP	/	/	/	/	/	/	SE	SE	SE	SE	SE
CAK	Cilindrico Ø 40 mm k6 Parallel keyed Ø 40 mm k6 [1.574 in k6]	/	/	/	/	/	/	/	ME	ME	/	/
CAJ	Cilindrico Ø 45 mm k6 Parallel keyed Ø 45 mm k6 [1.771 in k6]	/	/	/	/	/	/	/	/	/	ME	/
SAP	Scanalato W45x2x21x9g DIN 5480 Splined W45x2x21x9g DIN 5480	/	/	/	/	/	/	/	/	/	ME	/
CAX	Cilindrico Ø 50 mm k6 Parallel keyed Ø 50 mm k6 [1.968 in k6]	/	/	/	/	/	/	/	/	/	/	ME
SAQ	Scanalato W50x2x24x9g DIN 5480 Splined W50x2x24x9g DIN 5480	/	/	/	/	/	/	/	/	/	/	ME

• Disponibile - Available / Non Disponibile - Not Available

- 1) Il valore ME indica che l'albero è disponibile solo per la versione ISO
The ME code means that the shaft is only available for the ISO version
- 2) Il valore SE indica che l'albero è disponibile solo per la versione SAE
The SE code means that the shaft is only available for the SAE version
- 3) Il valore ME-SE indica che l'albero è disponibile sia per la versione ISO che SAE
The ME-SE code means that the shaft is available for the ISO and SAE version

1	2	3	4	5	6	7	8	9	10	10A	11	12	13

		006	012	020	030	040	055	075	090	108	160	226
7 - COPERCHI DISTRIBUTORI / PORT COVER												
LM1	Bocche Lateralì (Motore) Lateral ports (Motor)	ME	ME	/	/	/	/	/	/	/	/	/
FP1	Bocche Frontali (Pompa) Frontal ports (Pump)	ME	ME	ME-SE	ME-SE	ME	ME	ME	ME	ME	/	/
FM1	Bocche Frontali (Motore) Frontal ports (Motor)	/	ME ⁽⁴⁾	ME	ME	ME	ME	ME	ME	ME	/	/
LM2	Bocche Lateralì (Motore) Lateral ports (Motor)	/	/	ME-SE	ME-SE	ME-SE	ME-SE	ME-SE	ME-SE	ME-SE	ME-SE	ME-SE
VM2 (*)	Bocche Lateralì affiancate (Motore) Lateral ports same side (Motor)	/	/	ME-SE	ME-SE	ME-SE	ME-SE	ME-SE	ME-SE	ME-SE	/	/
LP1	Bocche Lateralì (Pompa) Lateral ports (Pump)	/	/	ME ⁽⁵⁾	ME ⁽⁵⁾	/	/	/	/	/	/	/
LP2	Bocche Lateralì (Pompa) Lateral ports (Pump)	/	/	/	/	ME-SE	ME-SE	ME-SE	ME-SE	ME-SE	/	/
FP2	Bocche Frontali (Pompa) Frontal ports (Pump)	/	/	/	/	/	/	/	/	/	ME-SE	ME-SE
FPM	Speciale FP2+LM2 (Pompa) Special FP2+LM2 (Pump)	/	/	/	/	/	/	/	/	/	/	ME
FLM	Speciale FM1+LM1 (Motore) Special FM1+LM1 (Motor)	/	ME ⁽⁴⁾	/	/	/	/	/	/	/	/	/

• Disponibile - Available / Non Disponibile - Not Available

(*) Le filettature del coperchio sono ISO anche nella versione SAE
The port cover threads are ISO also in SAE option

- Il valore ME indica che il coperchio è disponibile solo per la versione ISO
The ME code means that the port cover is only available for the ISO version
- Il valore SE indica che il coperchio è disponibile solo per la versione SAE
The SE code means that the port cover is only available for the SAE version
- Il valore ME-SE indica che il coperchio è disponibile sia per la versione ISO che SAE
The ME-SE code means that the port cover is available for the ISO and SAE version
- Speciale a richiesta
Special on request
- Fuori produzione
Out of production

		006	012	020	030	040	055	075	090	108	160	226
8 - SENSO DI ROTAZIONE (VISTA LATO ALBERO) / DIRECTION OF ROTATION (VIEWED FROM SHAFT SIDE)												
RV	Reversibile (Motore) Reversible (Motor)	•	•	•	•	•	•	•	•	•	•	•
DX	Destra (Pompa) CW (Pump)	•	•	•	•	•	•	•	•	•	•	•
SX	Sinistra (Pompa) CCW (Pump)	•	•	•	•	•	•	•	•	•	•	•
9 - TENUTE / SEALS												
N	NBR	•	•	•	•	•	•	•	•	•	•	•
V	FKM	•	•	•	•	•	•	•	•	•	•	•
10 - VALVOLE / VALVES												
XXXX	Non Richieste NONE	•	•	•	•	•	•	•	•	•	•	•
VCDM	Valvola controllo discesa VCD/M VCD/M Pilot assisted overcentre valve	/	/	VM2	VM2	VM2	VM2	VM2	VM2	VM2	/	/
VCD1	Valvola controllo discesa VCD/1 VCD/1 Pilot assisted overcentre valve	/	/	LM2	LM2	LM2	LM2	LM2	LM2	LM2	LM2	LM2
VCD2	Valvola controllo discesa VCD/2 VCD/2 Pilot assisted overcentre valve	/	/	/	/	/	/	LM2	LM2	LM2	LM2	LM2
VCR1	Valvola controllo rotazione VCR1 D/AF VCR1 D/AF Double acting overcentre valve	/	/	VM2	VM2	/	/	/	/	/	/	/
VCR3	Valvola controllo rotazione VCR3 VCR3 Double acting overcentre valve	/	/	/	/	VM2	/	/	/	/	/	/
VU16	Valvola unidirezionale VU165 VU165 Check valve	/	/	LM2	LM2	/	/	/	LM2	LM2	/	/
VSD1	Valvola antiurto VSD 120 VSD 120 anti-shock valve	/	/	/	/	/	/	/	/	/	LM2	LM2

• Disponibile - Available

/ Non Disponibile - Not Available

Le valvole sono disponibili solo con coperchi distributori ISO, per versione SAE contattare Uff. Tecnico.

Le valvole VU16 e VSD1 non sono disponibili con le valvole di lavaggio

The valves are available with ISO port cover only, please contact Technical department for SAE version

The VU16 and VSD1 are not available with flushing valve.

- Il valore VM2 indica che la valvola è disponibile solo con coperchio VM2
The VM2 code means that the valve is only available with VM2 port cover
- Il valore LM2 indica che la valvola è disponibile solo con coperchio LM2
The LM2 code means that the valve is only available with LM2 port cover

1	2	3	4	5	6	7	8	9	10	10A	11	12	13

10A - CARATTERISTICA VALVOLA / VALVES FEATURE		VALVOLE / VALVES							
		XXXX	VCDM	VCD1	VCD2	VCR1	VCR3	VU16	VSD1
000	Caratteristica non necessaria Feature not necessary	•	/	/	/	/	/	/	/
001	Non Tarata (Campo Taratura 30-350 bar) (Rapporto di pilotaggio 6.2:1) Not Set 30-350 bar [435 to 5075 psi] [Piloting ratio 6.2:1] - Control of rotation CW	/	/	/	/	•	/	/	/
004	Non Tarata (Campo Taratura 30-350 bar) (Rapporto di pilotaggio 6.2:1) - Controllo in rotazione DX Not Set 30-350 bar [435 to 5075 psi] [Piloting ratio 6.2:1] - Control of rotation CW	/	•	/	/	/	/	/	/
005	Non Tarata (Campo Taratura 30-350 bar) (Rapporto di pilotaggio 6.2:1) - Controllo in rotazione SX Not Set 30-350 bar [435 to 5075 psi] [Piloting ratio 6.2:1] - Control of rotation CCW	/	•	/	/	/	/	/	/
002	Non Tarata (Campo Taratura 0-350 bar)(Rapporto di pilotaggio 2.9:1) - Controllo in rotazione DX Not Set 0-350 bar [0 to 5075 psi][Piloting ratio 2.9:1] - Control of rotation CW	/	/	•	/	/	/	/	/
006	Non Tarata (Campo Taratura 0-350 bar)(Rapporto di pilotaggio 2.9:1) - Controllo in rotazione SX Not Set 0-350 bar [0 to 5075 psi][Piloting ratio 2.9:1] - Control of rotation CCW	/	/	•	/	/	/	/	/
003	Non Tarata (Campo Taratura 250-500 bar)(Rapporto di pilotaggio 13:1) - Controllo in rotazione DX Not Set 250-500 bar [3625 to 7250 psi][Piloting ratio 13:1] - Control of rotation CW	/	/	/	•	/	/	/	/
007	Non Tarata (Campo Taratura 250-500 bar)(Rapporto di pilotaggio 13:1) - Controllo in rotazione SX Not Set 250-500 bar [3625 to 7250 psi][Piloting ratio 13:1] - Control of rotation CCW	/	/	/	•	/	/	/	/
008	Non Tarata (Taratura Massima 350 bar, Portata Massima 65 l/min) - Controllo in rotazione DX Not Set (Max setting 350 bar[5075 psi], Max Flow 65 l/min [17.2 U.S. gpm]) - Control of rotation CW	/	/	/	/	/	/	•	/
009	Non Tarata (Taratura Massima 350 bar, Portata Massima 65 l/min) - Controllo in rotazione SX Not Set (Max setting 350bar[5075 psi], Max Flow 65l/min[17.2 U.S. gpm]) - Control of rotation CCW	/	/	/	/	/	/	•	/
010	Non Tarata (Taratura Massima 350 bar) - Controllo in rotazione DX Not Set (Max setting 350 bar [5075 psi]) - Control of rotation CW	/	/	/	/	/	/	/	•
011	Non Tarata (Taratura Massima 350 bar) - Controllo in rotazione SX Not Set (Max setting 350 bar [5075 psi]) - Control of rotation CCW	/	/	/	/	/	/	/	•
012	Non Tarata (Rapporto di pilotaggio 8:1) Not Set [Piloting ratio 8:1]	/	/	/	/	/	/	•	/

• Disponibile - Available / Non Disponibile - Not Available

Per la fornitura di valvole tarate contattare Uff. Tecnico.
Please contact Technical department for valve which require specific setting

Per le caratteristiche vedere il catalogo valvole
For the technical specifications see catalogue valves

		006	012	020	030	040	055	075	090	108	160	226
11 - VALVOLE DI LAVAGGIO / FLUSHING VALVES												
XX	Non Richieste NONE	•	•	•	•	•	•	•	•	•	•	•
06	Valvola di lavaggio VSC/F - 6 l/min VSC/F Flushing valve - 6 l/min [1.58 U.S. gpm]	/	/	LM2-VM2	LM2-VM2	LM2-VM2	LM2-VM2	LM2-VM2	LM2-VM2	LM2-VM2	LM2	LM2
09	Valvola di lavaggio VSC/F - 10.5 l/min VSC/F Flushing valve - 10.5 l/min [2.77 U.S. gpm]	/	/	LM2-VM2	LM2-VM2	LM2-VM2	LM2-VM2	LM2-VM2	LM2-VM2	LM2-VM2	LM2	LM2
15	Valvola di lavaggio VSC/F - 15 l/min VSC/F Flushing valve - 15 l/min [3.96 U.S. gpm]	/	/	LM2-VM2	LM2-VM2	LM2-VM2	LM2-VM2	LM2-VM2	LM2-VM2	LM2-VM2	LM2	LM2
21	Valvola di lavaggio VSC/F - 20 l/min VSC/F Flushing valve - 20 l/min [5.28 U.S. gpm]	/	/	LM2-VM2	LM2-VM2	LM2-VM2	LM2-VM2	LM2-VM2	LM2-VM2	LM2-VM2	LM2	LM2

• Disponibile - Available / Non Disponibile - Not Available

Non è possibile combinare le valvole di lavaggio con le valvole in pos. 10
It is not possible to combine the flushing valves with valve in pos.10

Per le caratteristiche vedere il catalogo valvole
For the technical specifications see catalogue valves

1	2	3	4	5	6	7	8	9	10	10A	11	12	13

		006	012	020	030	040	055	075	090	108	160	226
12 - CARATTERISTICHE SPECIALI / SPECIAL FEATURE												
XX	Nessuna Caratteristica NONE	•	•	• ¹⁾	• ¹⁾	• ⁵⁾	• ⁵⁾	• ⁵⁾	• ⁵⁾	• ⁵⁾	•	•
01	Guarnizione speciale albero 5 bar Special shaft seal 5 bar [72.5 psi]	/	/	• ²⁾	• ²⁾	• ⁶⁾	• ⁶⁾	/	/	/	•	•
03	Versione SAE con coperchio ISO SAE Version with ISO port cover	/	/	• ³⁾	• ³⁾	• ⁷⁾	• ⁷⁾	• ⁷⁾	• ⁷⁾	• ⁷⁾	• ⁸⁾	• ⁸⁾
02	Guarnizione speciale albero 20 bar Special shaft seal 20 bar [290 psi]	/	/	•	•	/	/	/	• ⁴⁾	• ⁴⁾	/	/
TC	Versione con Tachimetro + Sensore Tachometer version + Sensor	/	/	• ⁴⁾	• ⁴⁾	/	/	/	/	/	/	/
T2	Guarnizione speciale albero 20 bar + Tachimetro con Sensore Special shaft seal 20 bar [290 psi] + Tachometer with Sensor	/	/	• ⁴⁾	• ⁴⁾	/	/	/	/	/	/	/

• Disponibile - Available / Non Disponibile - Not Available

- 1) Non disponibile in versione SAE con coperchi FP1 e VM2.
Not available with SAE version and FP1 / VM2 port cover.
- 2) Solo con tenute in NBR e non disponibile in versione SAE con coperchi FP1 e VM2.
Only with NBR seals and not available with SAE version and FP1 / VM2 port cover.
- 3) Disponibile con coperchi FP1 - FM1 - VM2.
Available with FP1 - FM1 - VM2 port cover.
- 4) Disponibile solo in versione ISO
Available only in ISO version.
- 5) Non disponibile in versione SAE con coperchi VM2.
Not available with SAE version and VM2 port cover.
- 6) Solo con tenute in NBR.
Only with NBR seals.
- 7) Disponibile con coperchi FM1 - VM2.
Available with FM1 - VM2 port cover.
- 8) Disponibile con coperchi LM2.
Available with LM2 port cover.

		006	012	020	030	040	055	075	090	108	160	226
13 - VERNICIATURA / PAINTING												
XX	Non Richieste NONE	•	•	•	•	•	•	•	•	•	•	•
01	Verniciato Nero RAL 9005 Black Painted RAL 9005	•	•	•	•	•	•	•	•	•	•	•
02	Verniciato Blu RAL 5015 Blue Painted RAL 5015	•	•	•	•	•	•	•	•	•	•	•

• Disponibile - Available / Non Disponibile - Not Available

S1, S2: Drenaggi (1 tappato) / Drain ports (1 plugged) - 3/8 G (BSPP)
 A, B: UtENZE / Service line ports
 S: Aspirazione / Suction port

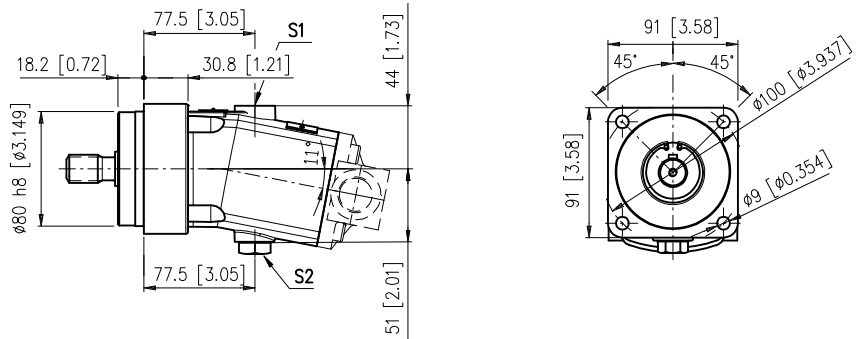

FP1

Per funzionamento come pompa (circuito aperto)
 For pump operation (open circuit)

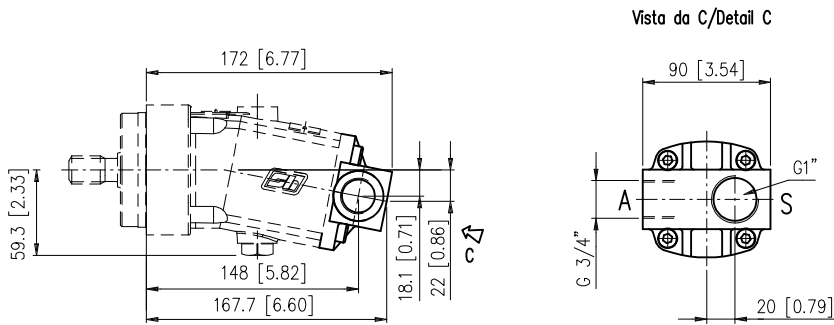

LM1

Per funzionamento come motore
 For motor operation

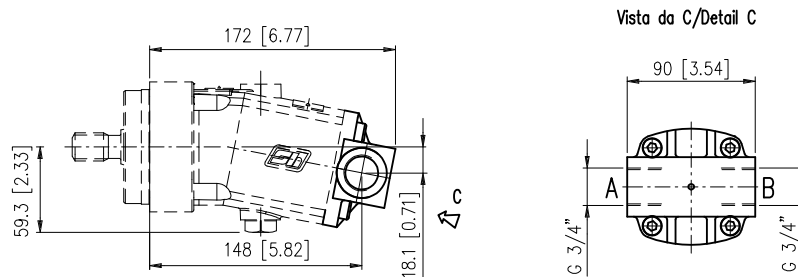

CAV

Albero cilindrico
 Parallel keyed shaft

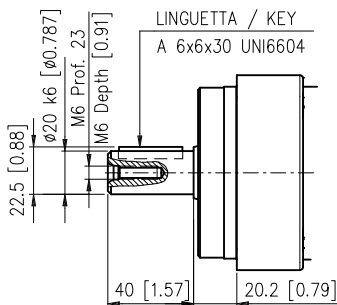

SAF

Albero scanalato
 Splined shaft

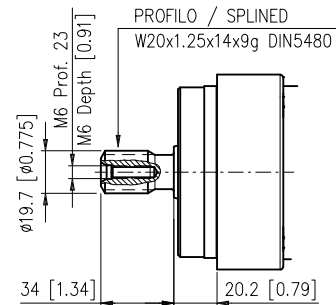

S1, S2: Drenaggi (1 tappato) / Drain ports (1 plugged) - 3/8 G (BSP)

A, B: Utenze / Service line ports

S: Aspirazione / Suction port

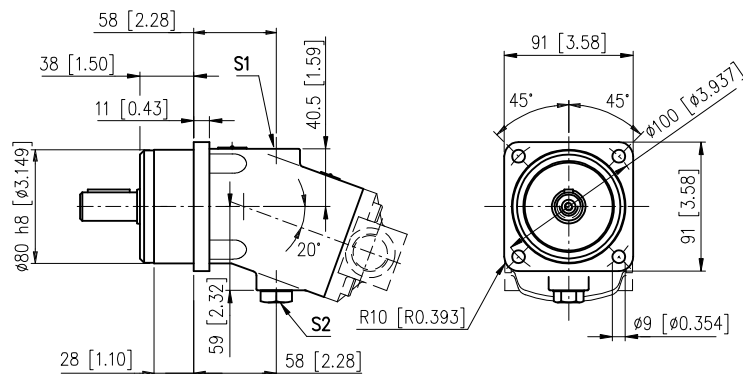

FP1

Per funzionamento come pompa (circuito aperto)
 For pump operation (open circuit)

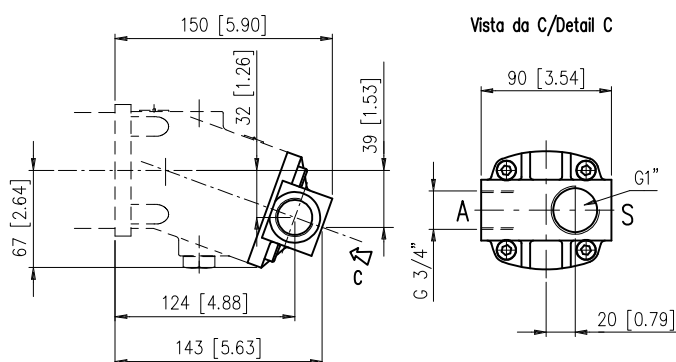

LM1

Per funzionamento come motore
 For motor operation

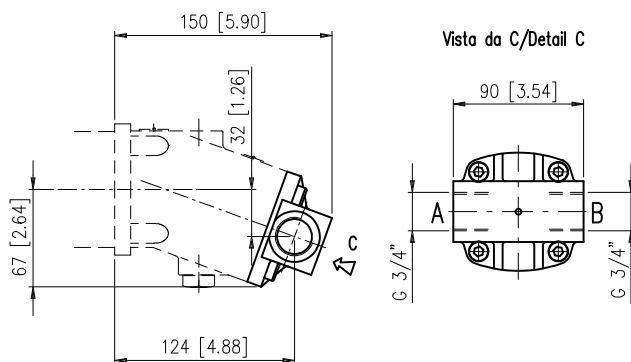

FM1

Per funzionamento come motore
 For motor operation

A RICHIESTA
 UPON REQUEST

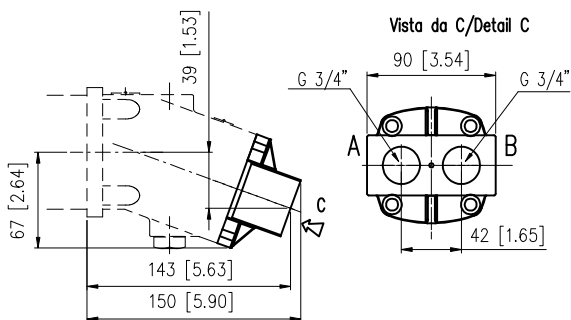

FLM

Per funzionamento come motore
 For motor operation

A RICHIESTA
 UPON REQUEST

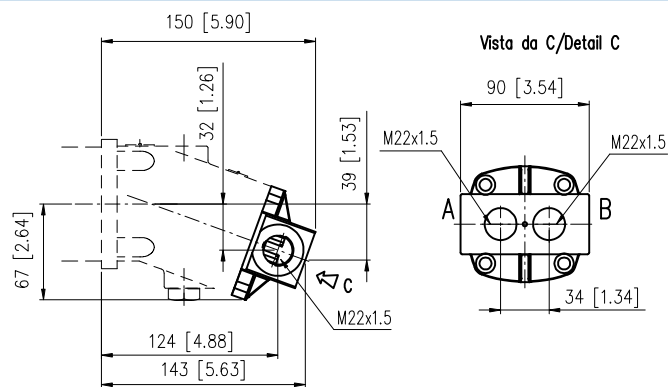

CAV

Albero cilindrico
 Parallel keyed shaft

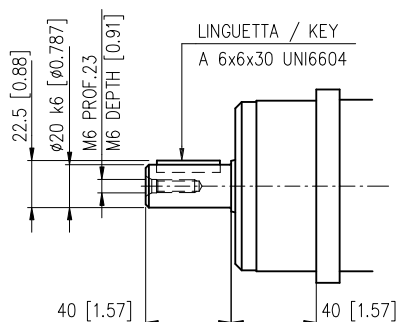

SAF

Albero scanalato
 Splined shaft

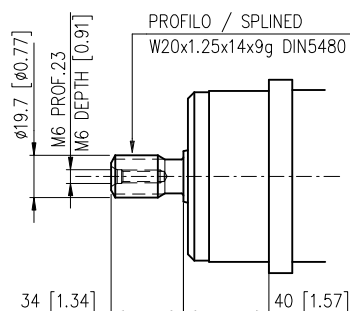

S1, S2: Drenaggi (1 tappato) / Drain ports (1 plugged) - 3/8 G (BSPP)
A, B: Utenze / Service line ports
S: Aspirazione / Suction port
R: Spurgo (tappato) / Air bleed (plugged) - 1/8 G (BSPP)

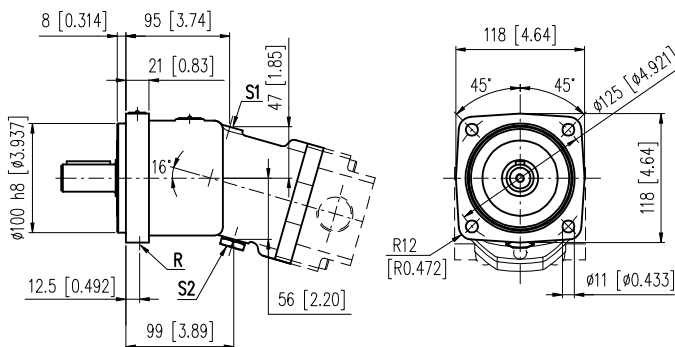

FP1

Per funzionamento come pompa (circuito aperto)
For pump operation (open circuit)

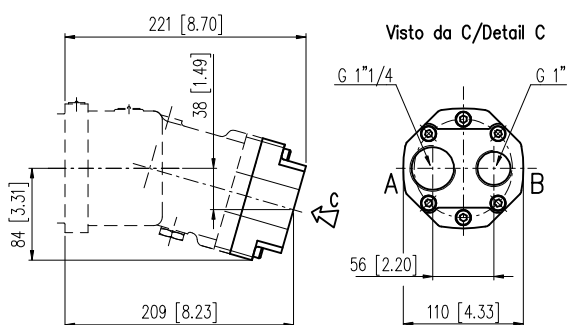

FM1

Per funzionamento come motore
For motor operation

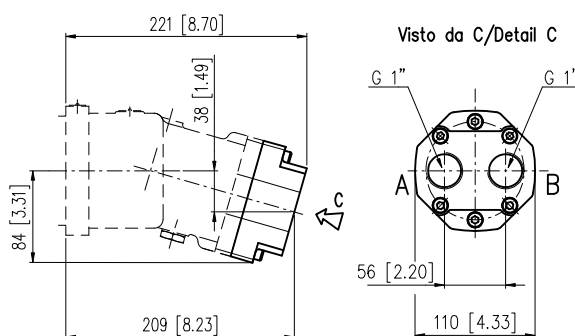

LM2

Per funzionamento come motore
For motor operation

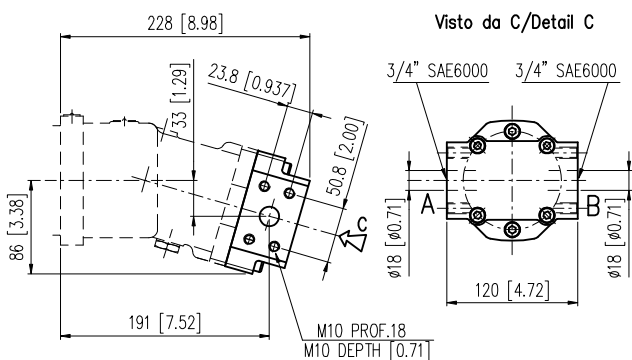

LP1

Per funzionamento come pompa (circuito aperto)
For pump operation (open circuit)

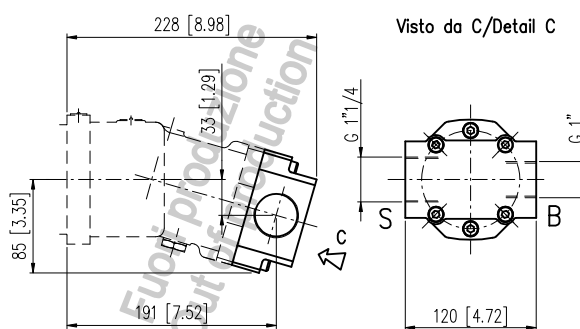

CBM

Albero cilindrico
Parallel keyed shaft

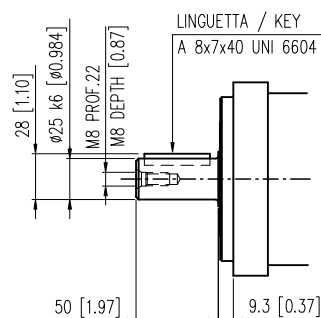

SAG

Albero scanalato
Splined shaft

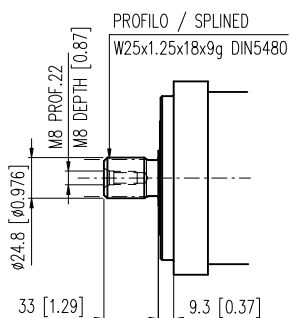

VM2

Per funzionamento come motore
For motor operation

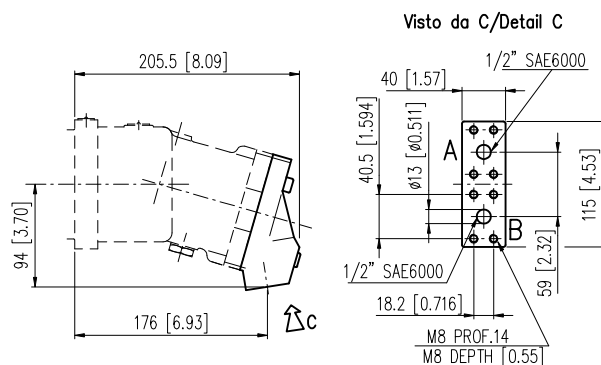

DIMENSIONI FLANGIA ISO 4 FORI (OB)
DIMENSIONS ISO 4 BOLTS FLANGE (OB)

H1C 030 ME

S1, S2: Drenaggi (1 tappato) G 3/8" / Drain ports (1 plugged) - 3/8 G (BSPP)
 A, B: Utenze / Service line ports
 S: Aspirazione / Suction port

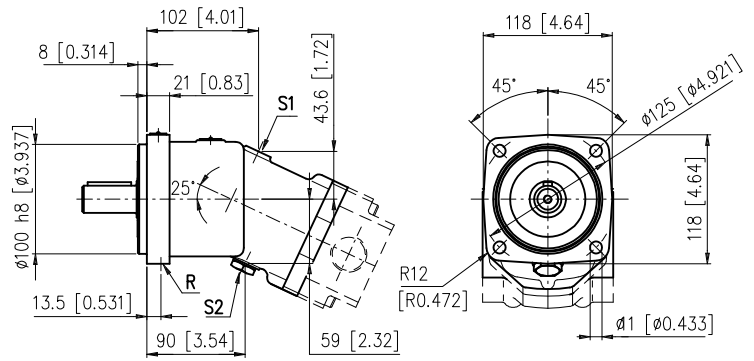

FP1

Per funzionamento come pompa (circuito aperto)
 For pump operation (open circuit)

FM1

Per funzionamento come motore
 For motor operation

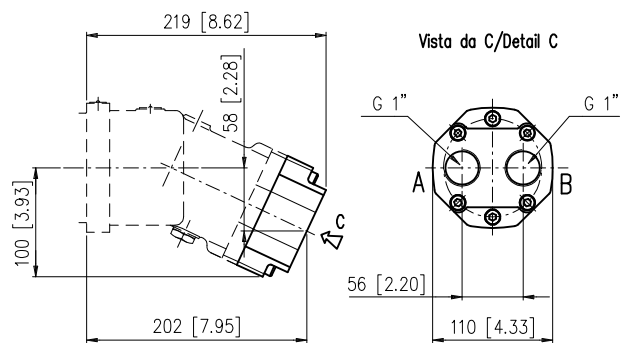
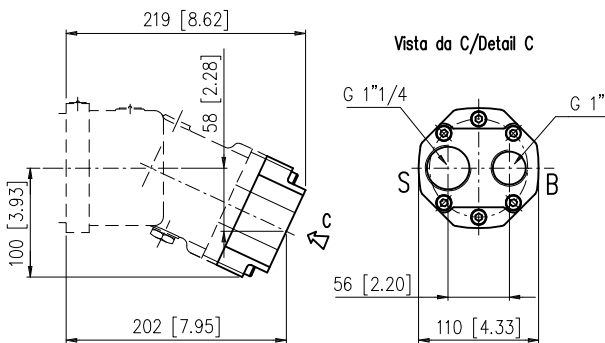

LP1

Per funzionamento come pompa (circuito aperto)
 For pump operation (open circuit)

LM2

Per funzionamento come motore
 For motor operation

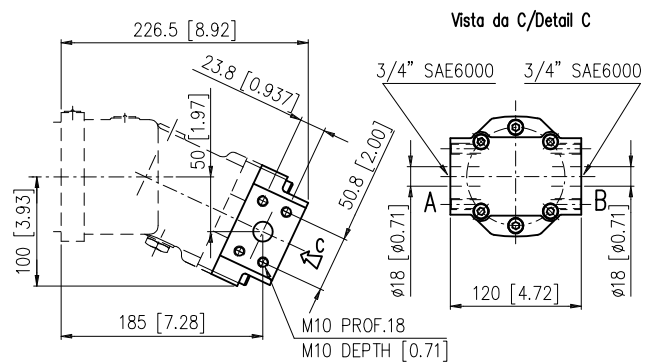
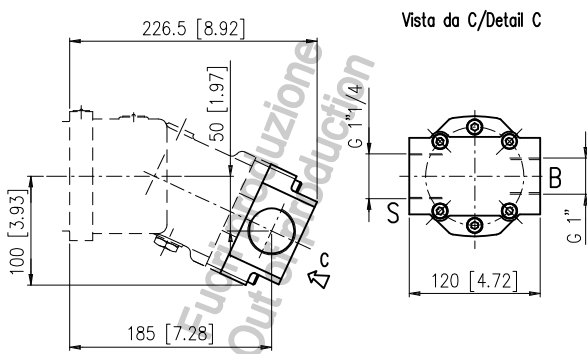

CBM

Albero cilindrico
 Parallel keyed shaft

SAG

Albero scanalato
 Splined shaft

VM2

Per funzionamento come motore
 For motor operation

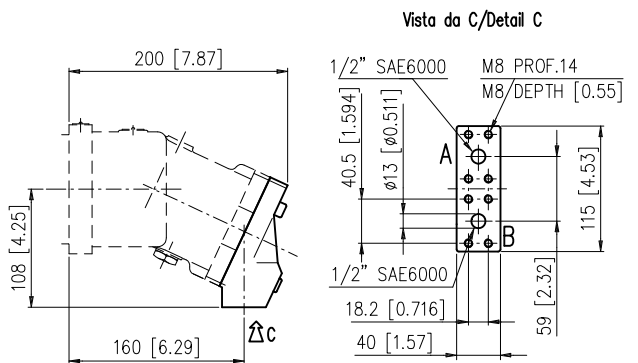
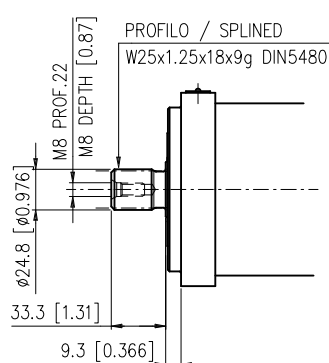
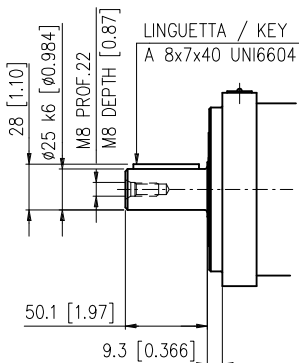

DIMENSIONI FLANGIA ISO 4 FORI (OC) DIMENSIONS ISO 4 BOLTS FLANGE (OC)

H1C 040 ME

S1, S2: Drenaggi (1 tappato) / Drain ports (1 plugged) - 1/2 G (BSPP)
A, B: Utenze / Service line ports
S: Aspirazione / Suction port
R: Spurgo (tappato) / Air bleed (plugged) - 1/8 G (BSPP)

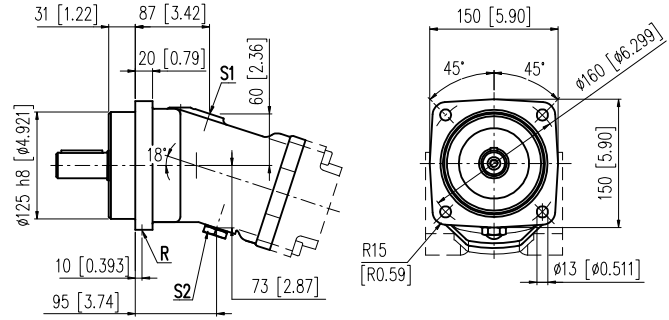

LP2

Per funzionamento come pompa (circuito aperto)
For pump operation (open circuit)

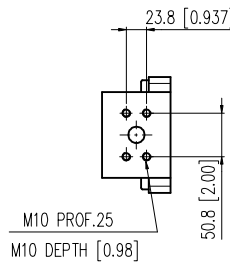
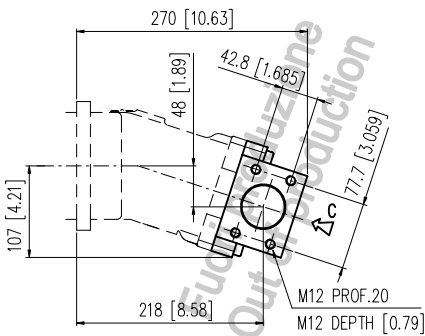

Vista da C/Detail C

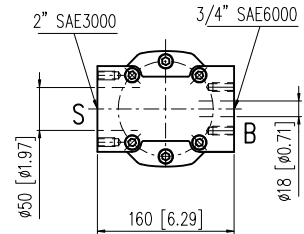

FM1-FP1

Per funzionamento come pompa (circuito aperto)/motore
For pump operation (open circuit)/motor

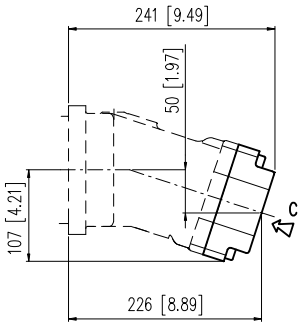

Vista da C/Detail C

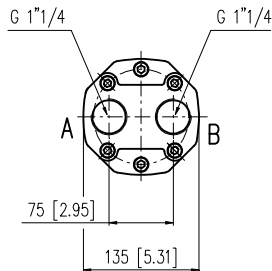

LM2

Per funzionamento come motore
For motor operation

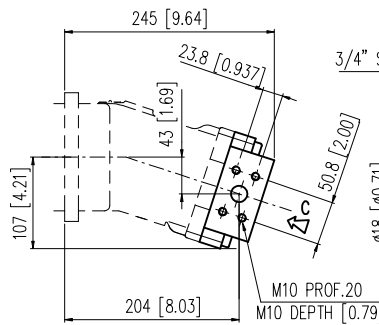

Vista da C/Detail C

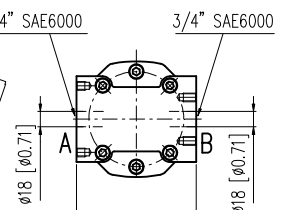

CAW

Albero cilindrico
Parallel keyed shaft

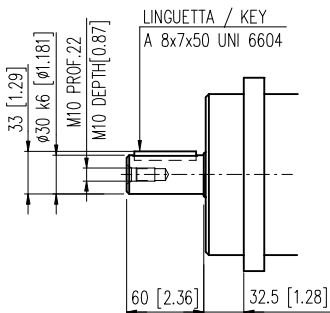

SAI

Albero scanalato
Splined shaft

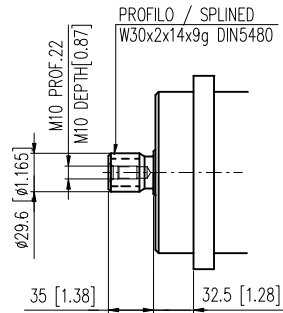

VM2

Per funzionamento come motore
For motor operation

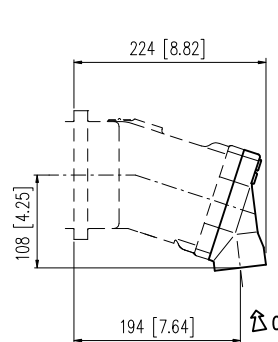

Vista da C/Detail C

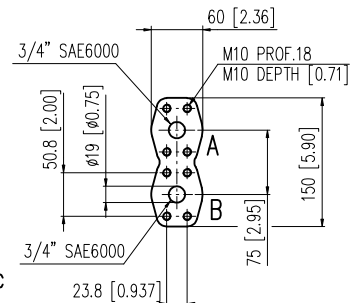

S1, S2: Drenaggi (1 tappato) / Drain ports (1 plugged) - 1/2 G (BSPP)
A, B: Utenze / Service line ports
S: Aspirazione / Suction port
R: Spurgo (tappato) / Air bleed (plugged) - 1/8 G (BSPP)



LP2

Per funzionamento come pompa (circuito aperto)
For pump operation (open circuit)

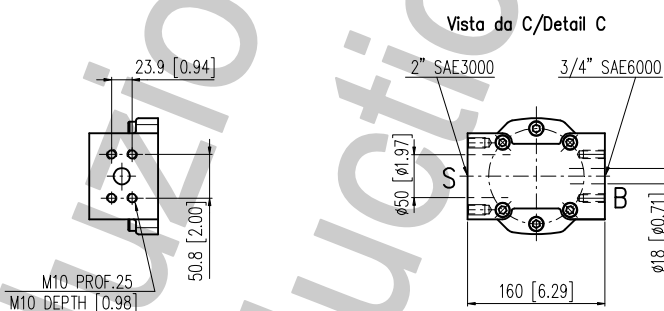
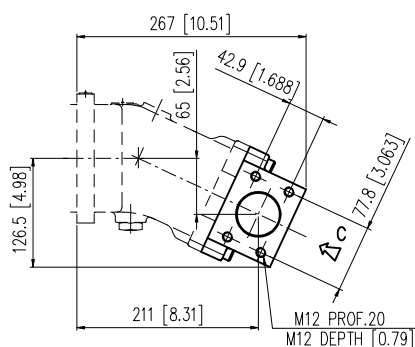

FM1-FP1

Per funzionamento come pompa (circuito aperto)/motore
For pump operation (open circuit)/motor

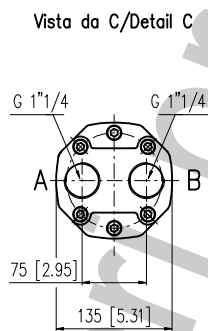
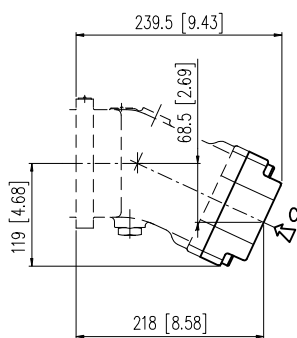

LM2

Per funzionamento come motore
For motor operation

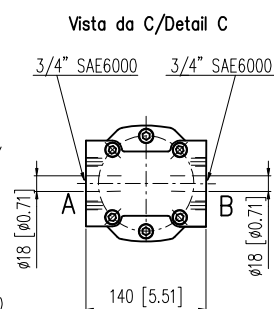
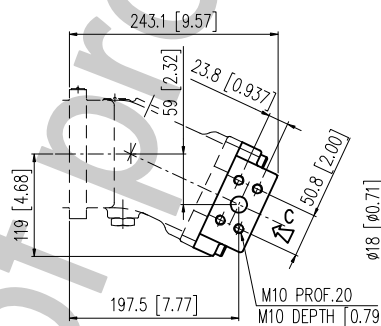

CAW

Albero cilindrico
Parallel keyed shaft

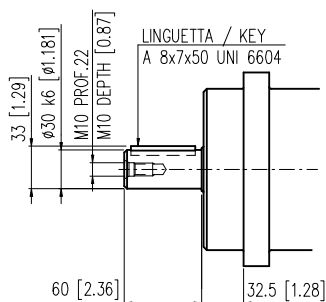

SAI

Albero scanalato
Splined shaft

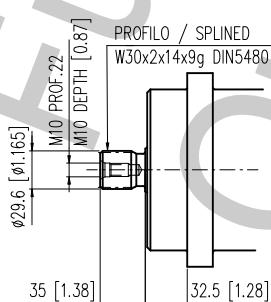

VM2

Per funzionamento come motore
For motor operation

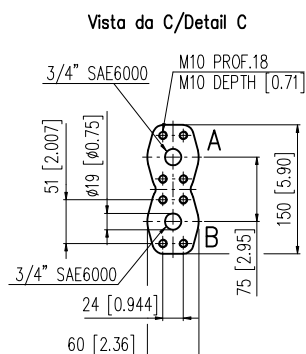
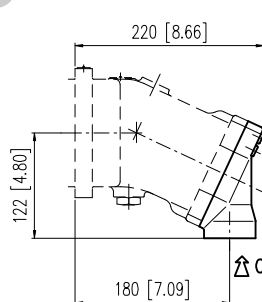

S1, S2: Drenaggi (1 tappato) / Drain ports (1 plugged) - 1/2 G (BSPP)
A, B: UtENZE / Service line ports
S: Aspirazione / Suction port
R: Spurgo (tappato) / Air bleed (plugged) - 1/8 G (BSPP)

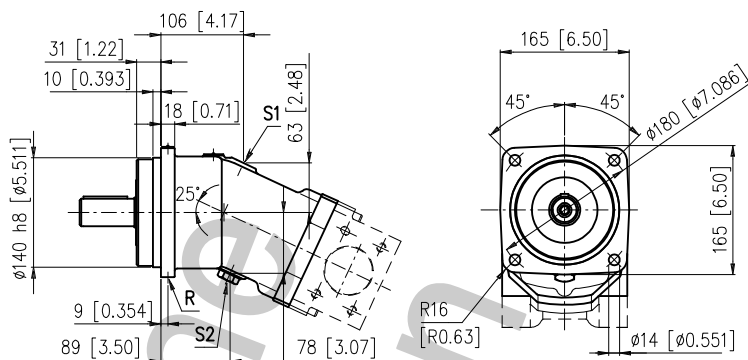

LP2

Per funzionamento come pompa (circuito aperto)
For pump operation (open circuit)

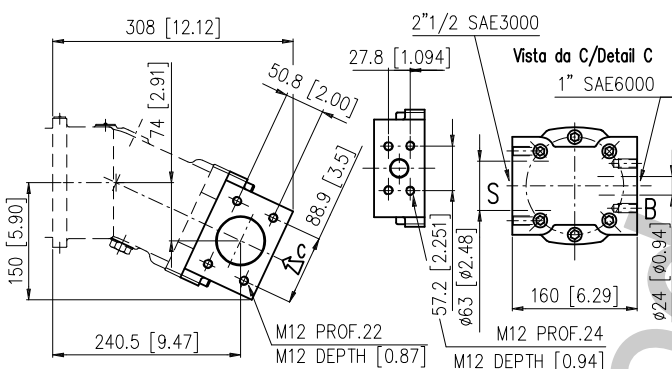

FM1-FP1

Per funzionamento come pompa (circuito aperto)/motore
For pump operation (open circuit)/motor

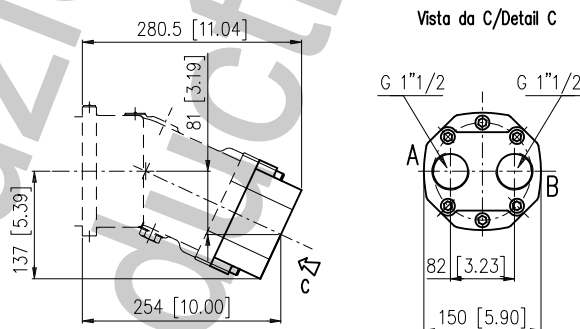

LM2

Per funzionamento come motore
For motor operation

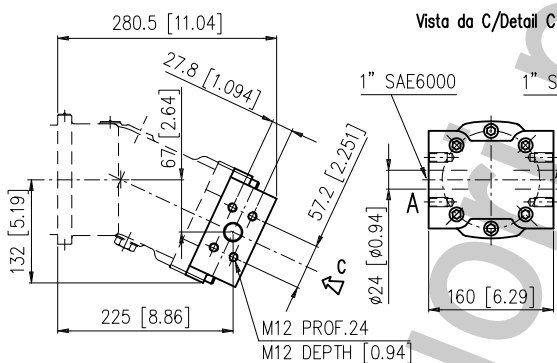

VM2

Per funzionamento come motore
For motor operation

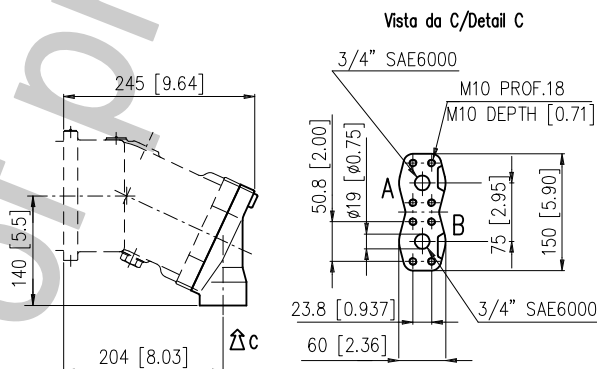

CAY

Albero cilindrico
Parallel keyed shaft

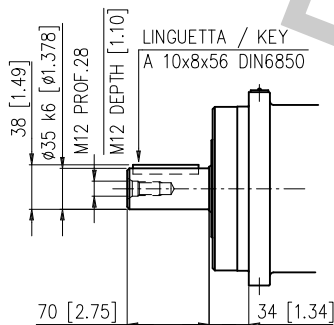

SAM

Albero scanalato
Splined shaft

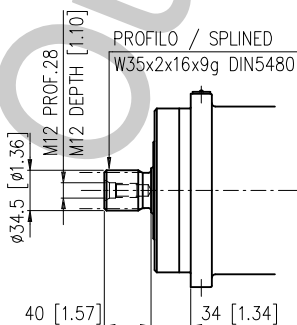

SAO

Albero scanalato
Splined shaft

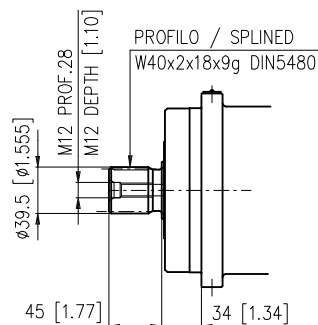

S1, S2: Drenaggi (1 tappato) / Drain ports (1 plugged) - 1/2 G (BSPP)
A, B: Utenze / Service line ports
S: Aspirazione / Suction port
R: Spurgo (tappato) / Air bleed (plugged) - 1/8 G (BSPP)

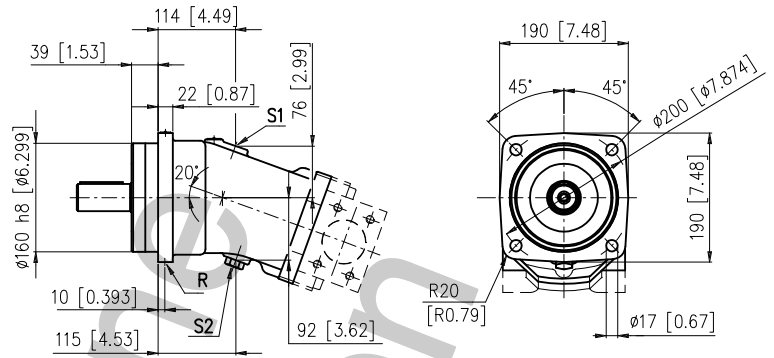

LP2

Per funzionamento come pompa (circuito aperto)
For pump operation (open circuit)

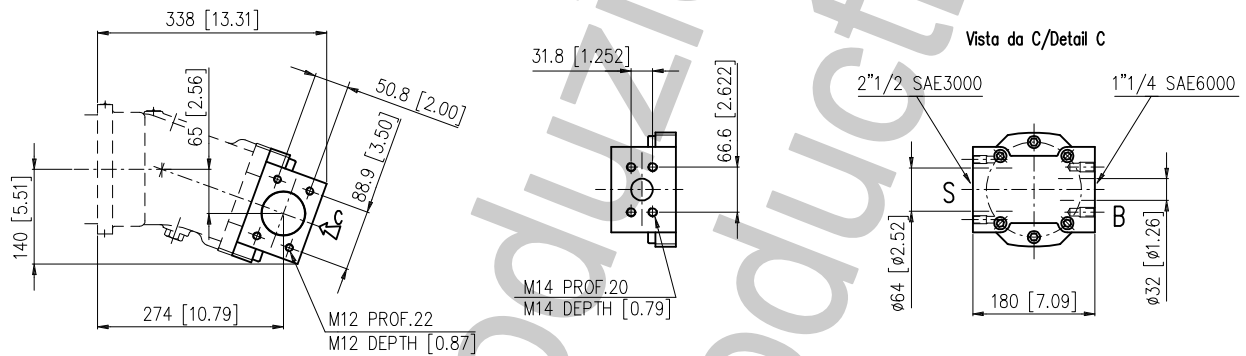

FM1-FP1

Per funzionamento come pompa (circuito aperto)/motore
For pump operation (open circuit)/motor

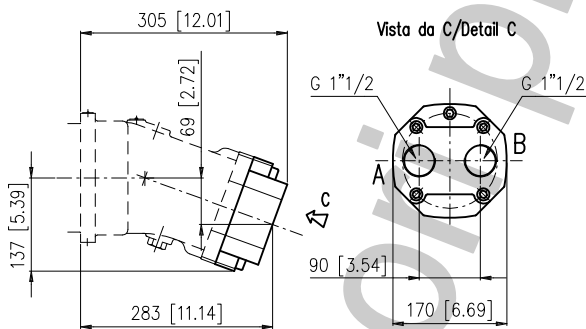

LM2

Per funzionamento come motore
For motor operation

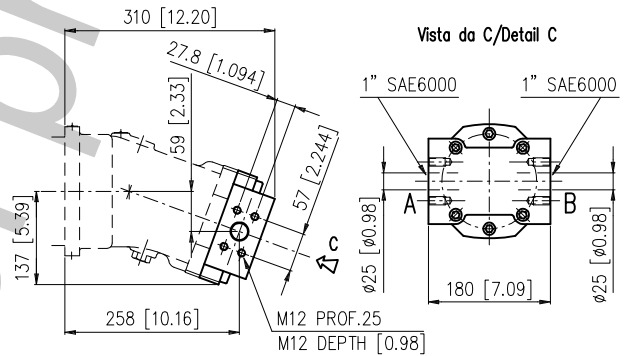

CAK

Albero cilindrico
Parallel keyed shaft

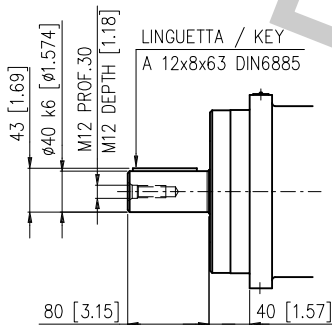

SAO

Albero scanalato
Splined shaft

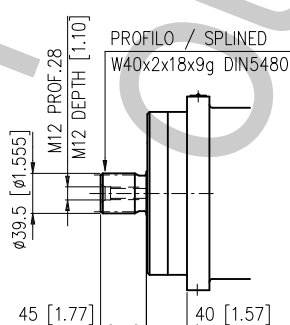

VM2

Per funzionamento come motore
For motor operation

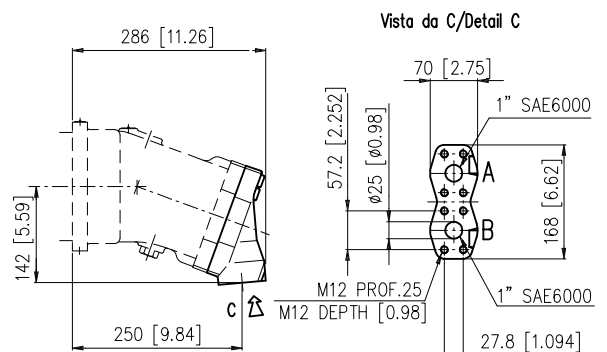

S1, S2: Drenaggi (1 tappato) / Drain ports (1 plugged) - 1/2 G (BSPP)
A, B: UtENZE / Service line ports
S: Aspirazione / Suction port
R: Spurgo (tappato) / Air bleed (plugged) - 1/8 G (BSPP)

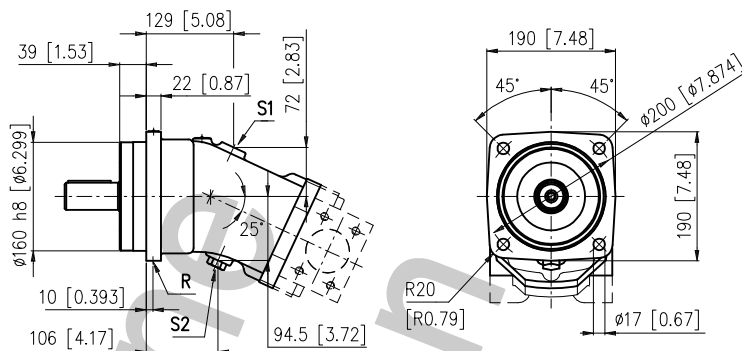

LP2

Per funzionamento come pompa (circuito aperto)
For pump operation (open circuit)

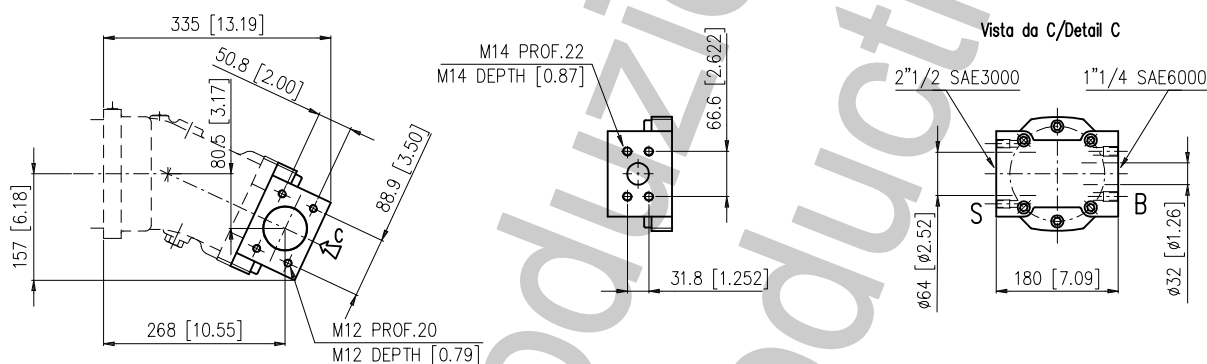

FM1-FP1

Per funzionamento come pompa (circuito aperto)/motore
For pump operation (open circuit)/motor

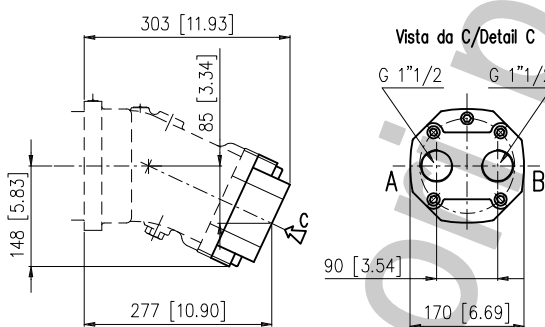

LM2

Per funzionamento come motore
For motor operation

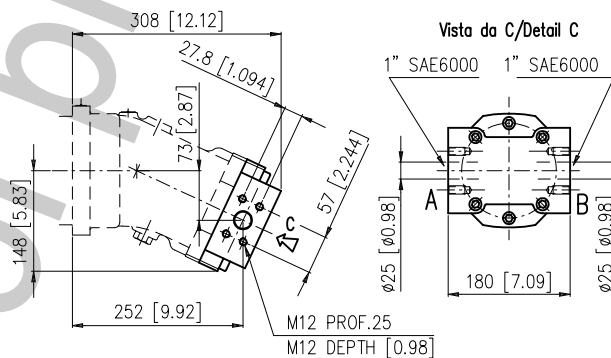

CAK

Albero cilindrico
Parallel keyed shaft

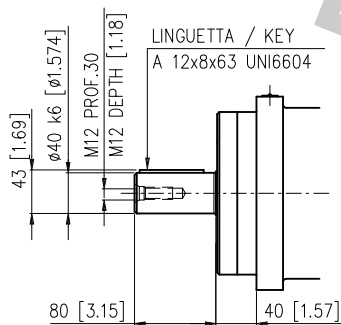

SAO

Albero scanalato
Splined shaft

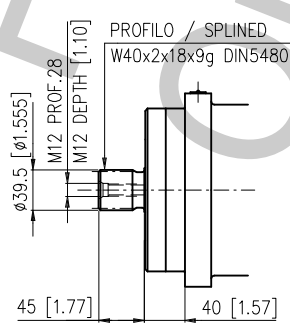

VM2

Per funzionamento come motore
For motor operation

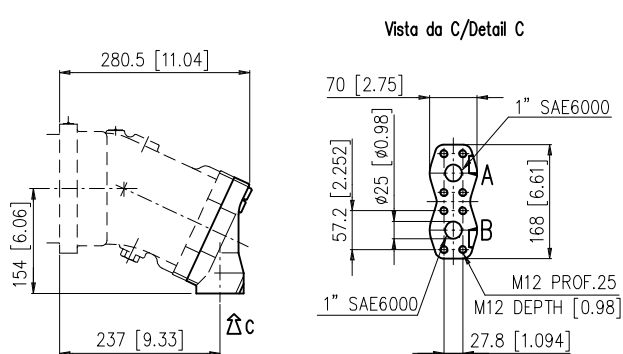

S1, S2: Drenaggi (1 tappato) / Drain ports (1 plugged) - 3/4 G (BSPP)
A, B: Utenze / Service line ports
S: Aspirazione / Suction port
R: Spurgo (tappato) / Air bleed (plugged) - 1/8 G (BSPP)

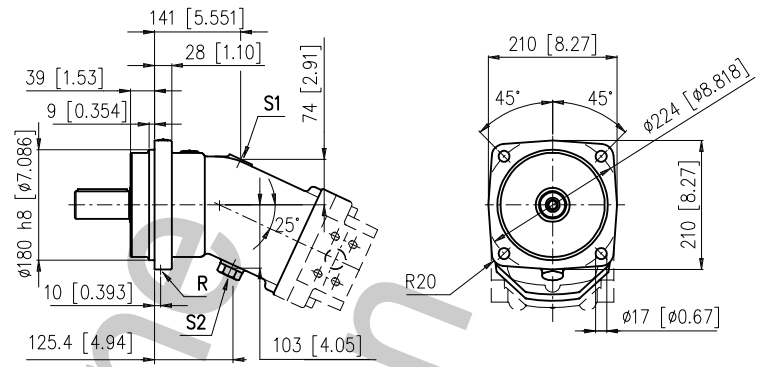

FP2

Per funzionamento come pompa (circuito aperto)
For pump operation (open circuit)

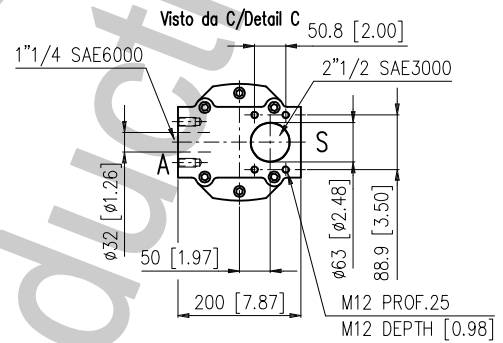
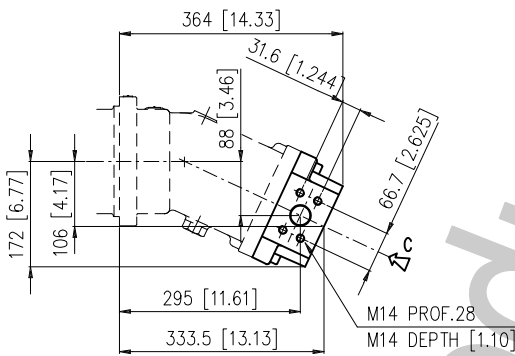

LM2

Per funzionamento come motore
For motor operation

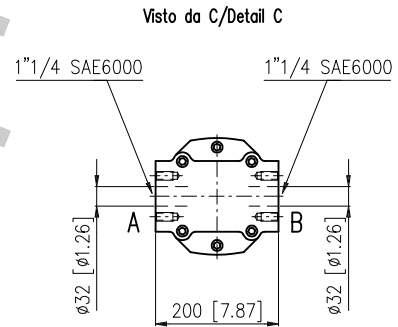
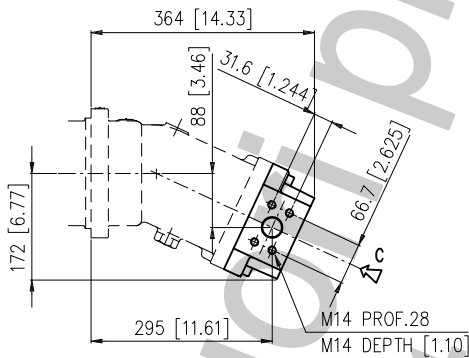

CAJ

Albero cilindrico
Parallel keyed shaft

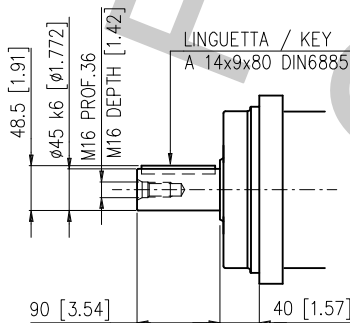

SAP

Albero scanalato
Splined shaft

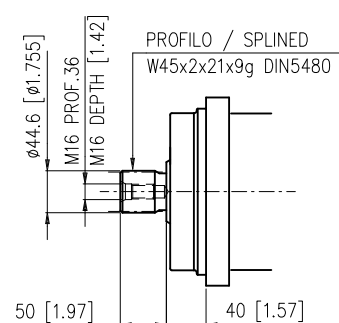

S1, S2: Drenaggi (1 tappato) / Drain ports (1 plugged) - 3/4 G (BSPP)
A, B: Utenze / Service line ports
S: Aspirazione / Suction port
R: Spurgo (tappato) / Air bleed (plugged) - 1/8 G (BSPP)

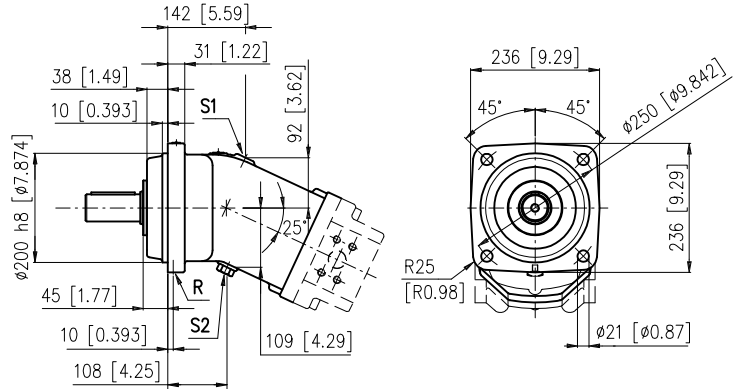

FP2

Per funzionamento come pompa (circuito aperto)
For pump operation (open circuit)

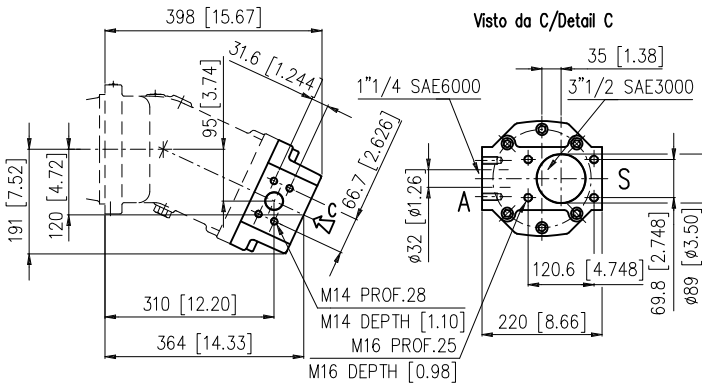

LM2

Per funzionamento come motore
For motor operation

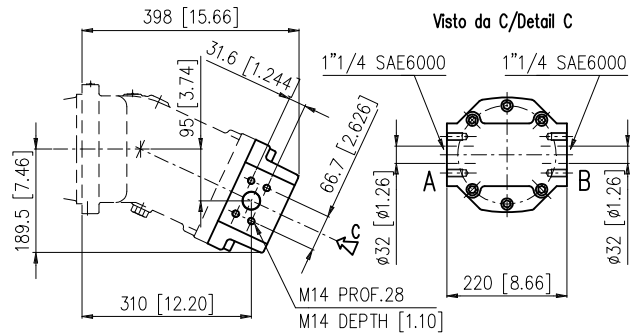

FPM

Per funzionamento come pompa
For pump operation

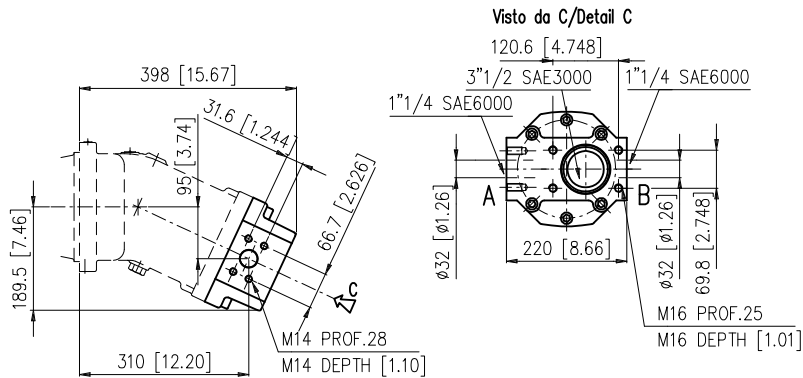

CAX

Albero cilindrico
Parallel keyed shaft

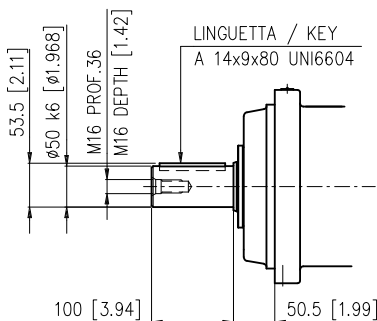

SAQ

Albero scanalato
Splined shaft

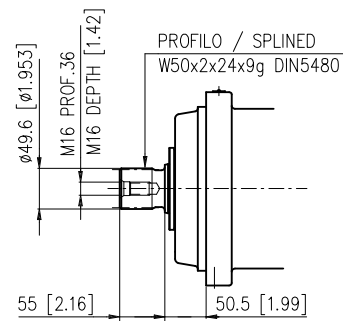

S1, S2: Drenaggi (1 tappato) / Drain ports (1 plugged) - 7/8"-14 UNF 2B
A, B: Utenze / Service line ports
S: Aspirazione / Suction port

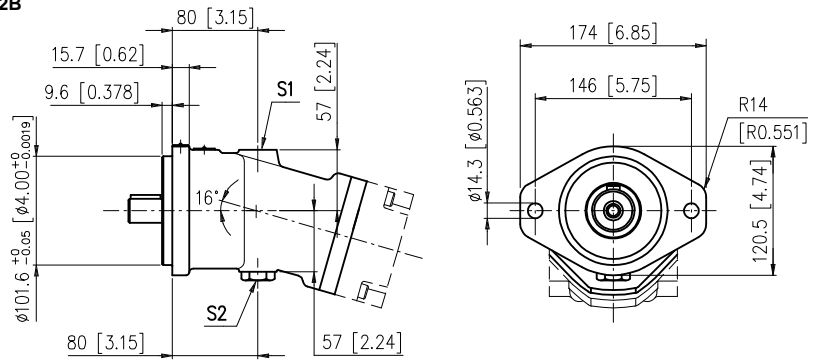

LM2

Per funzionamento come motore
For motor operation

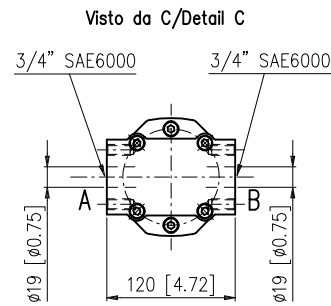
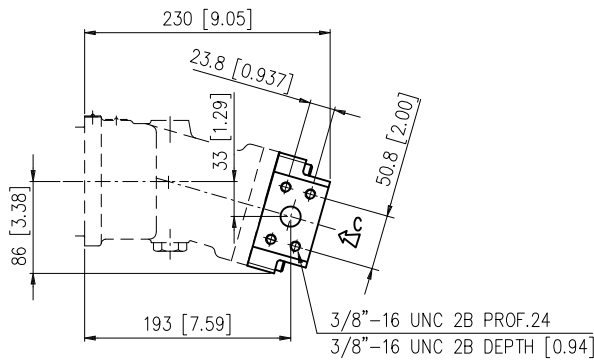

C16

Albero cilindrico
Parallel keyed shaft

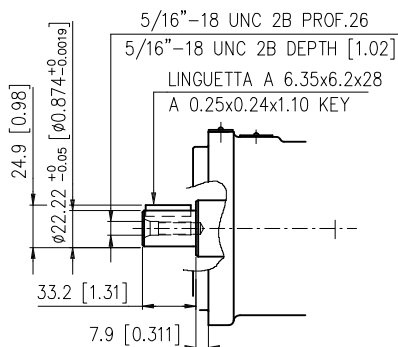

S05

Albero scanalato
Splined shaft

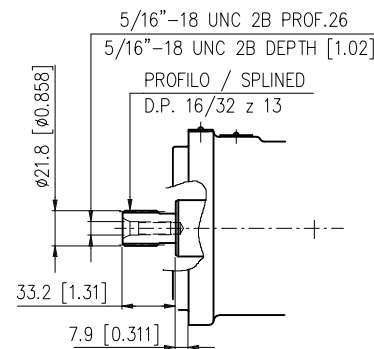

S1, S2: Drenaggi (1 tappato) / Drain ports (1 plugged) - 7/8"-14 UNF 2B
 A, B: Utenze / Service line ports
 S: Aspirazione / Suction port

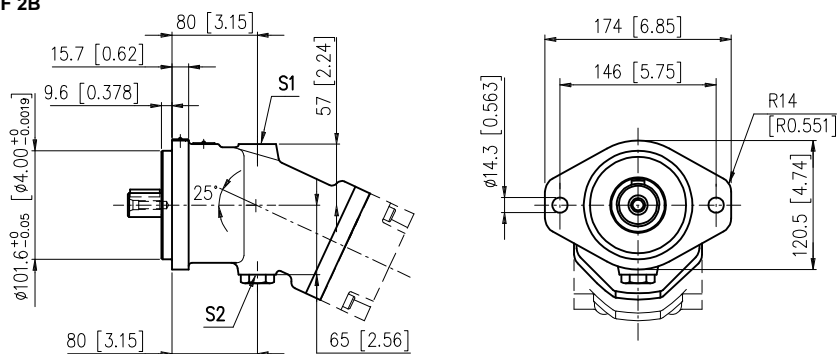

LM2

Per funzionamento come motore
 For motor operation

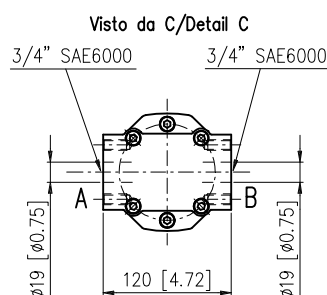
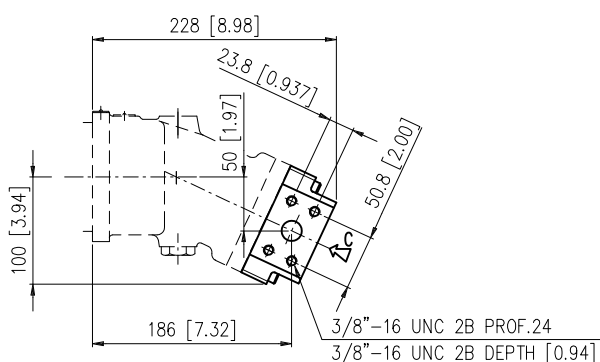

C16

Albero cilindrico
 Parallel keyed shaft

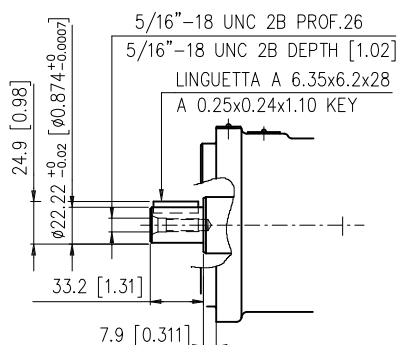

S05

Albero scanalato
 Splined shaft

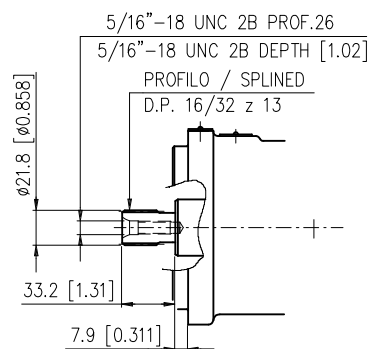

S1, S2: Drenaggi (1 tappato) / Drain ports (1 plugged) - 1" 1/16-12 UN 2B
 A, B: UtENZE / Service line ports
 S: Aspirazione / Suction port

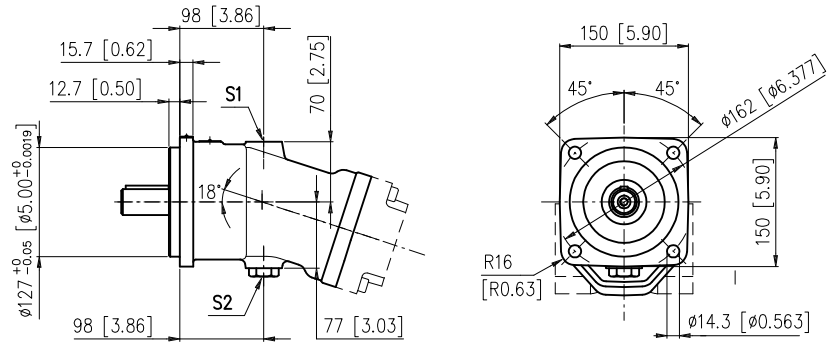

LP2

Per funzionamento come pompa (circuito aperto)
 For pump operation (open circuit)

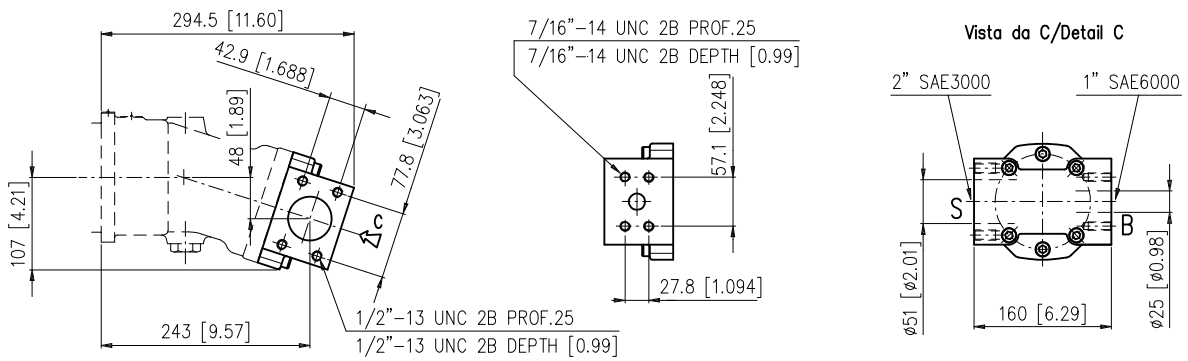

LM2

Per funzionamento come motore
 For motor operation

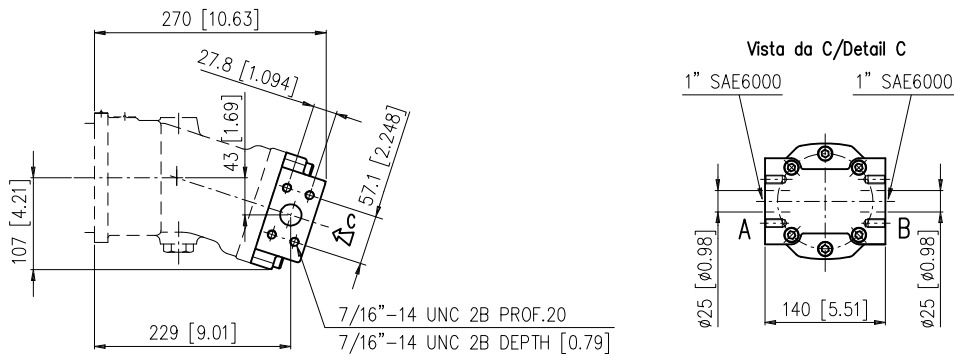

C17

Albero cilindrico
 Parallel keyed shaft

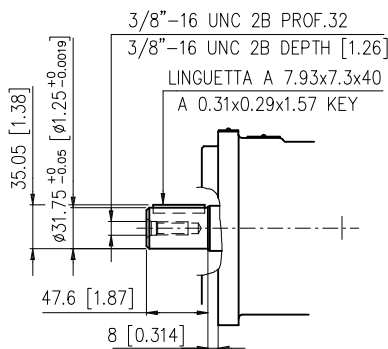

S12

Albero scanalato
 Splined shaft

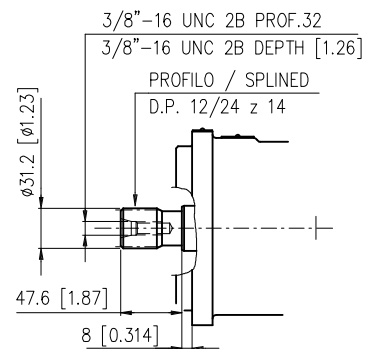

S1, S2: Drenaggi (1 tappato) / Drain ports (1 plugged) - 1" 1/16-12 UN 2B
 A, B: Utenze / Service line ports
 S: Aspirazione / Suction port

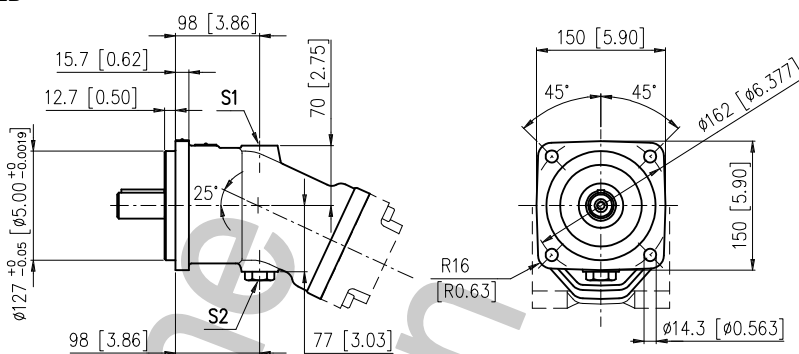

LP2

Per funzionamento come pompa (circuito aperto)
 For pump operation (open circuit)

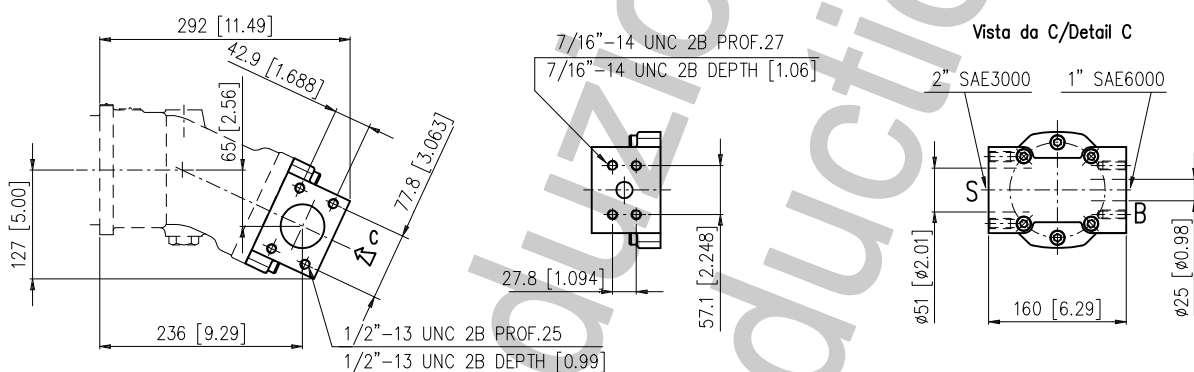

LM2

Per funzionamento come motore
 For motor operation

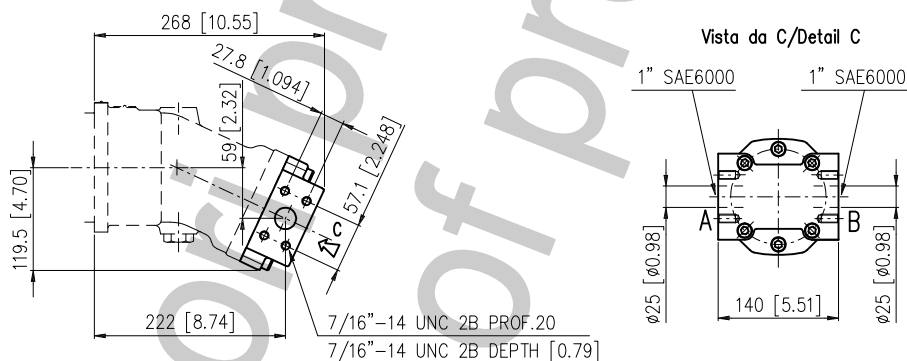

C17

Albero cilindrico
 Parallel keyed shaft

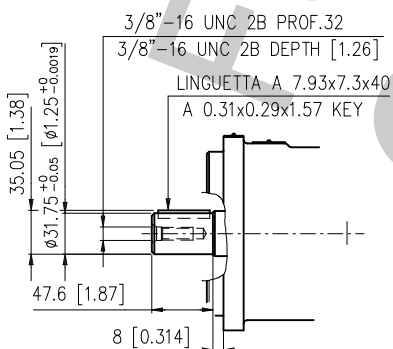

S12

Albero scanalato
 Splined shaft

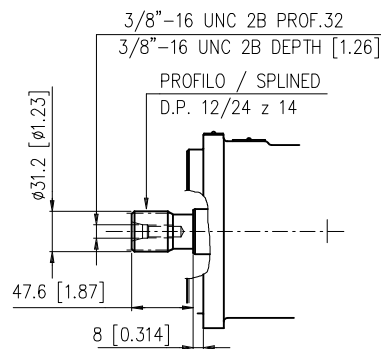

S1, S2: Drenaggi (1 tappato) / Drain ports (1 plugged) - 1" 1/16-12 UN 2B
 A, B: Utenze / Service line ports
 S: Aspirazione / Suction port

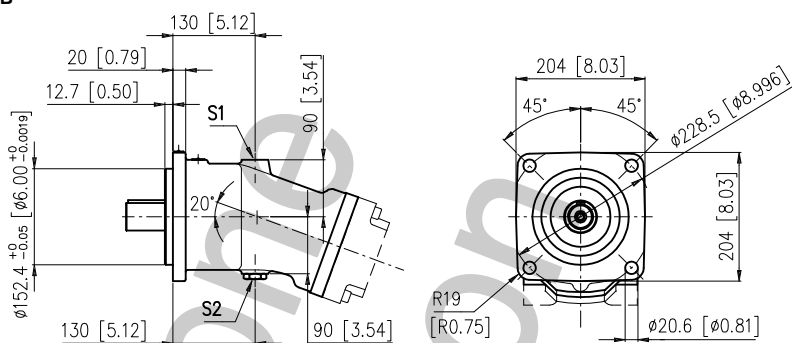

LP2

Per funzionamento come pompa (circuito aperto)
 For pump operation (open circuit)

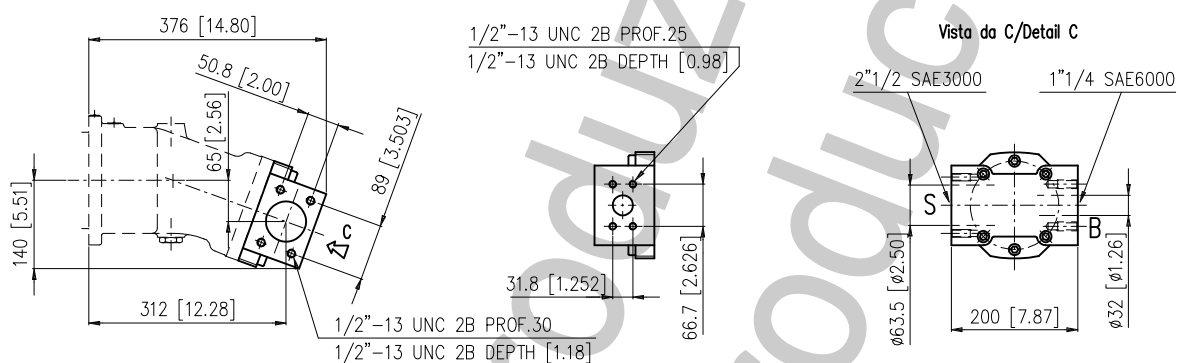

LM2

Per funzionamento come motore
 For motor operation

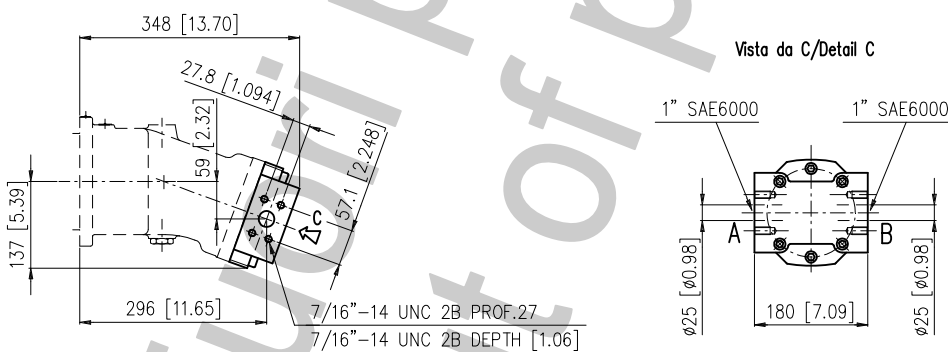

C18

Albero cilindrico
 Parallel keyed shaft

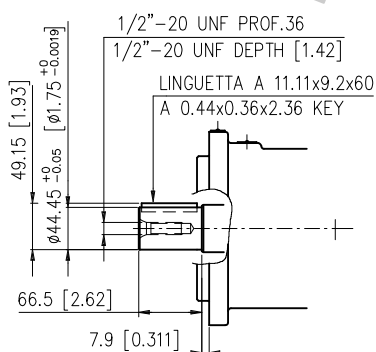

S15

Albero scanalato
 Splined shaft

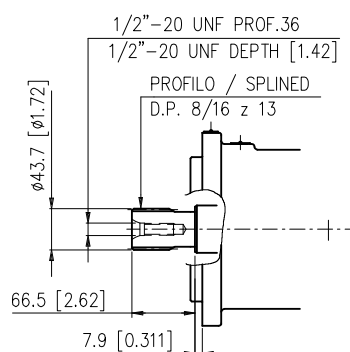

S1, S2: Drenaggi (1 tappato) / Drain ports (1 plugged) - 1" 1/16-12 UN 2B
A, B: Utenze / Service line ports
S: Aspirazione / Suction port
R: Spurgo (tappato) / Air bleed (plugged) - 7/16-20 UNF

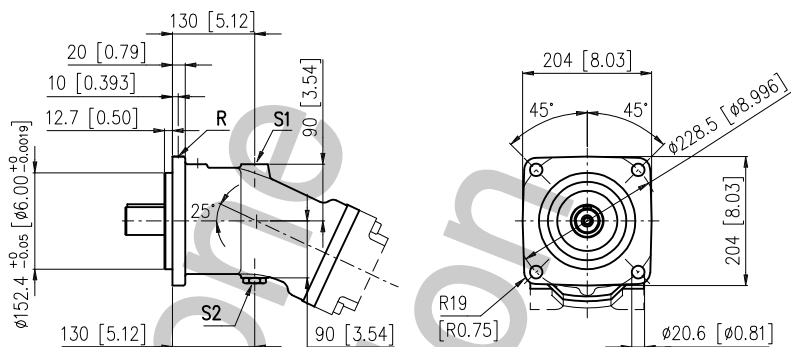

LP2

Per funzionamento come pompa (circuito aperto)
For pump operation (open circuit)

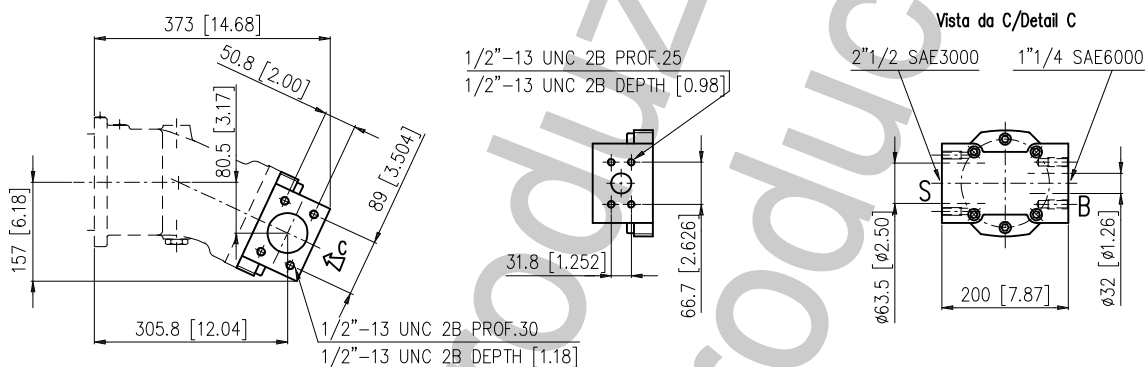

LM2

Per funzionamento come motore
For motor operation

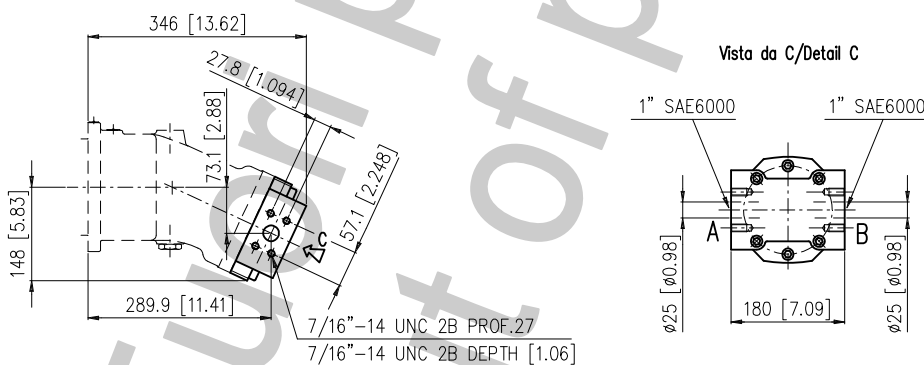

C18

Albero cilindrico
Parallel keyed shaft

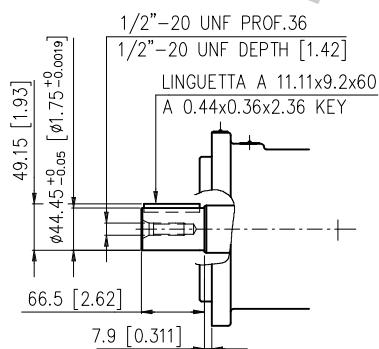

S15

Albero scanalato
Splined shaft

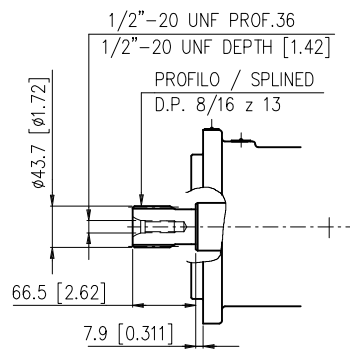

DIMENSIONI FLANGIA SAE D 4 FORI (08)
DIMENSIONS SAE D 4 BOLTS FLANGE (08)

H1C 160 SE

S1, S2: Drenaggi (1 tappato) / Drain ports (1 plugged) - 1" 3/16-12 UN 2B
 A, B: Utenze / Service line ports
 S: Aspirazione / Suction port
 R: Spurgo (tappato) / Air bleed (plugged) - 7/16"-20 UNF

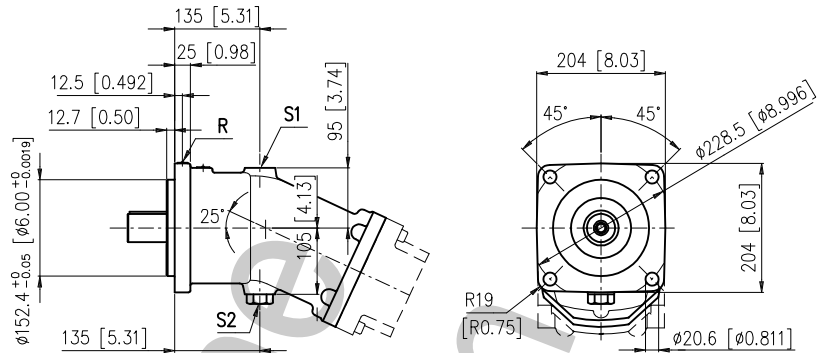

FP2

Per funzionamento come pompa (circuito aperto)
 For pump operation (open circuit)

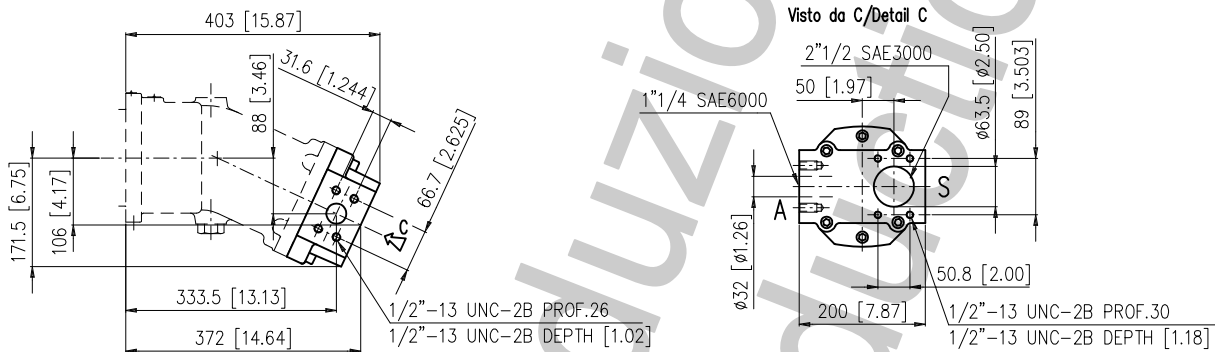

LM2

Per funzionamento come motore
 For motor operation

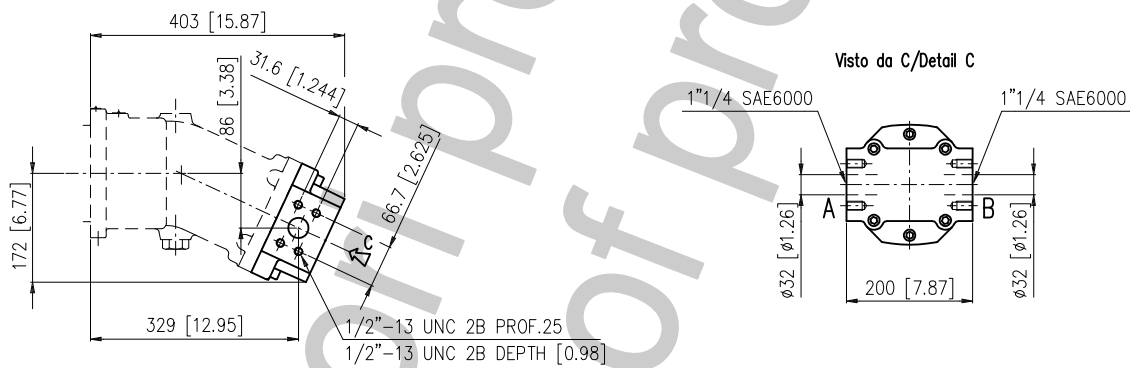

C18

Albero cilindrico
 Parallel keyed shaft

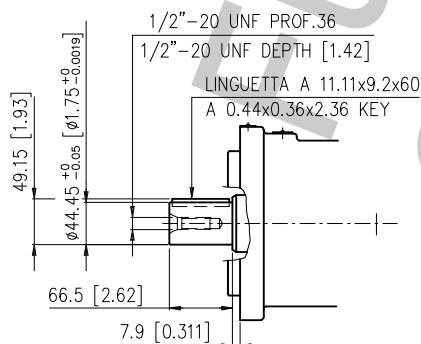

S15

Albero scanalato
 Splined shaft

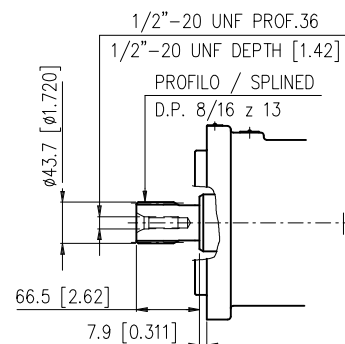

S1, S2: Drenaggi (1 tappato) / Drain ports (1 plugged) - 1" 3/16-12 UN 2B
A, B: Utenze / Service line ports
S: Aspirazione / Suction port
R: Spurgo (tappato) / Air bleed (plugged) - 7/16"-20 UNF

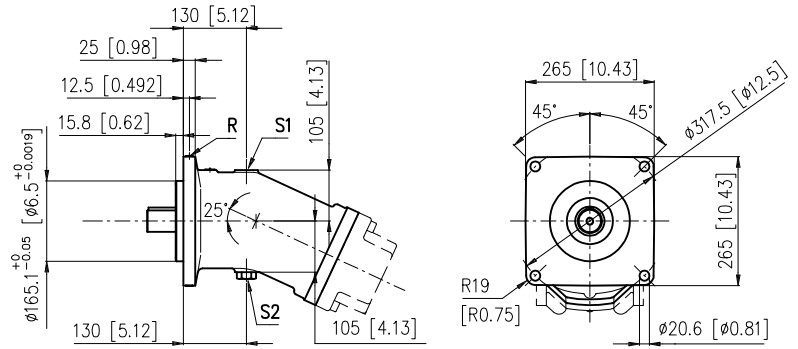

FP2

Per funzionamento come pompa (circuito aperto)
For pump operation (open circuit)

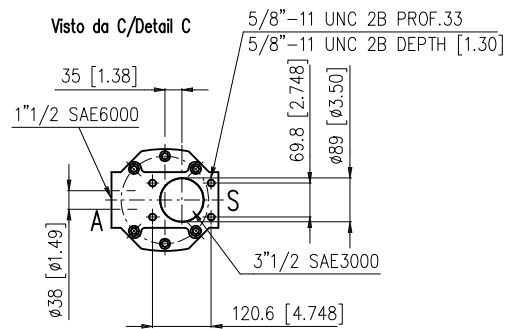
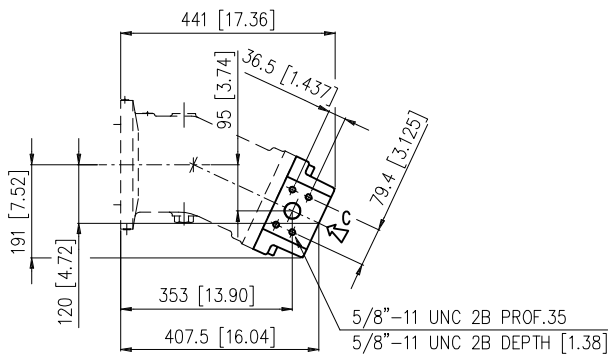

LM2

Per funzionamento come motore
For motor operation

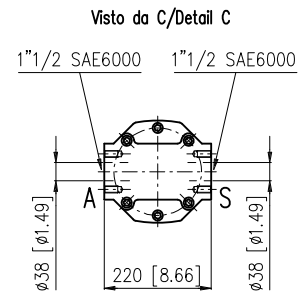
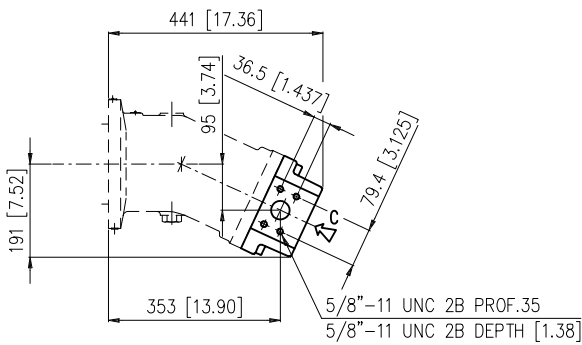

C18

Albero cilindrico
Parallel keyed shaft

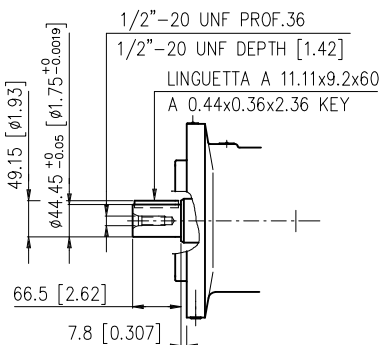

S15

Albero scanalato
Splined shaft

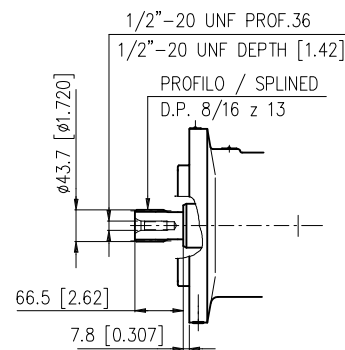

VERSIONE CON TACHIMETRO TACHOMETER VERSION

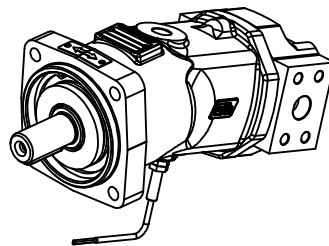
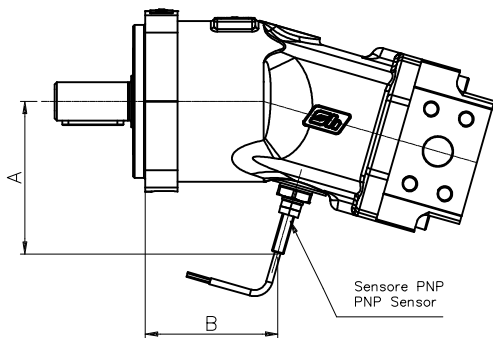

	H1C 020	H1C 030
A mm [in]	99.7 [3.92]	100.5 [3.95]
B mm [in]	86.6 [3.41]	71.1 [2.79]

Segnale in uscita versione elettronica Output signal electronic tachometer

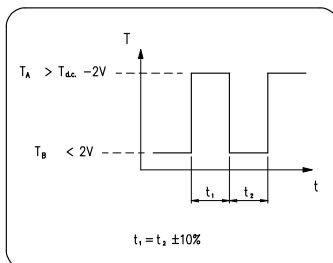

- Numero d'impulsi per giro = 14
- Principio di funzionamento induttivo
- Funzione di uscita PNP
- Tensione nominale 10-30 V d.c.
- Caricabilità massima 200 mA
- Frequenza massima 1500 Hz
- Campo di temperatura -25°C +120°C
- Grado di protezione IP 67
- Versioni disponibili:
- Sensore con cavo a tre fili lunghezza 2 metri

- Number of pulses per revolution = 14
- Inductive principle
- Output current PNP
- Voltage 10-30 V d.c.
- Max load 200 mA
- Max frequency 1500 Hz
- Temperature range -25°C +120°C
- Enclosure IP 67
- Available versions:
- Sensor with 2 metres three wires cable

La versione con Tachimetro è disponibile solo in versione ISO.
Il sensore può essere montato solo sull'attacco drenaggio S2.

The Tachometer version is only available in ISO version. The sensor can be assembly only S2 drain port.

Brevini Fluid Power S.p.A. Tutti i diritti riservati. Hydr-App, SAM Hydraulik, Aron, Brevini Hydraulics, BPE Electronics, VPS Brevini, OT Oiltechnology, sono marchi o marchi registrati di Brevini Fluid Power S.p.A. o da altre società del Gruppo Brevini in Italia ed in altri paesi.

Le caratteristiche tecniche fornite nel presente catalogo non sono impegnative e non sarà possibile basare alcun procedimento legale su tale materiale. Brevini Fluid Power non sarà responsabile per informazioni e specifiche che possano indurre ad errori o errate interpretazioni. Data la continua ricerca tecnologica volta a migliorare le caratteristiche tecniche dei nostri prodotti, Brevini Fluid Power si riserva il diritto di apportarvi senza alcun preavviso le modifiche che riterrà opportuno. E' vietata la riproduzione anche parziale senza la specifica autorizzazione scritta di Brevini Fluid Power. Questo catalogo sostituisce i precedenti.

L'utilizzo dei prodotti riportati su questo catalogo deve essere effettuato nel rispetto dei limiti di funzionamento riportati nelle specifiche tecniche, valutando il tipo di applicazione e le condizioni di funzionamento normali o in caso di avaria, in modo da non pregiudicare la sicurezza di persone e/o cose.

Condizioni generali di vendita: vedere sito www.brevinifluidpower.com.

I prodotti illustrati su questo catalogo fanno parte della linea  **SAMHYDRAULIK**

Brevini Fluid Power S.p.A. All rights reserved. Hydr-App, SAM Hydraulik, Aron, Brevini Hydraulics, BPE Electronics, VPS Brevini, OT Oiltechnology, logos are trademarks or are registered trademarks of Brevini Fluid Power S.p.A. or other companies of the Brevini Group in Italy and other countries.

The technical features supplied in this catalogue are non binding and no legal action can be taken against such material. Brevini Fluid Power will not be held responsible for information and specifications which may lead to error or incorrect interpretations. Given the continuous technical research aimed at improved technical features of our products, Brevini Fluid Power reserves the right to make change that are considered appropriate without any prior notice. This catalogue cannot be reproduced (in whole or in part) without the prior written consent of Brevini Fluid Power. This catalogue supersedes all previous ones.

Use of the products in this catalogue must comply with the operating limits given in the technical specifications. The type of application and operating conditions must be assessed as normal or in malfunction in order to avoid endangering the safety of people and/or items.

General terms and conditions of sale: see website www.brevinifluidpower.com.

The products shown on this catalog are parts of  **SAMHYDRAULIK** line.