

 **brevini**

HIGH TORQUE S SERIES

BROCHURE

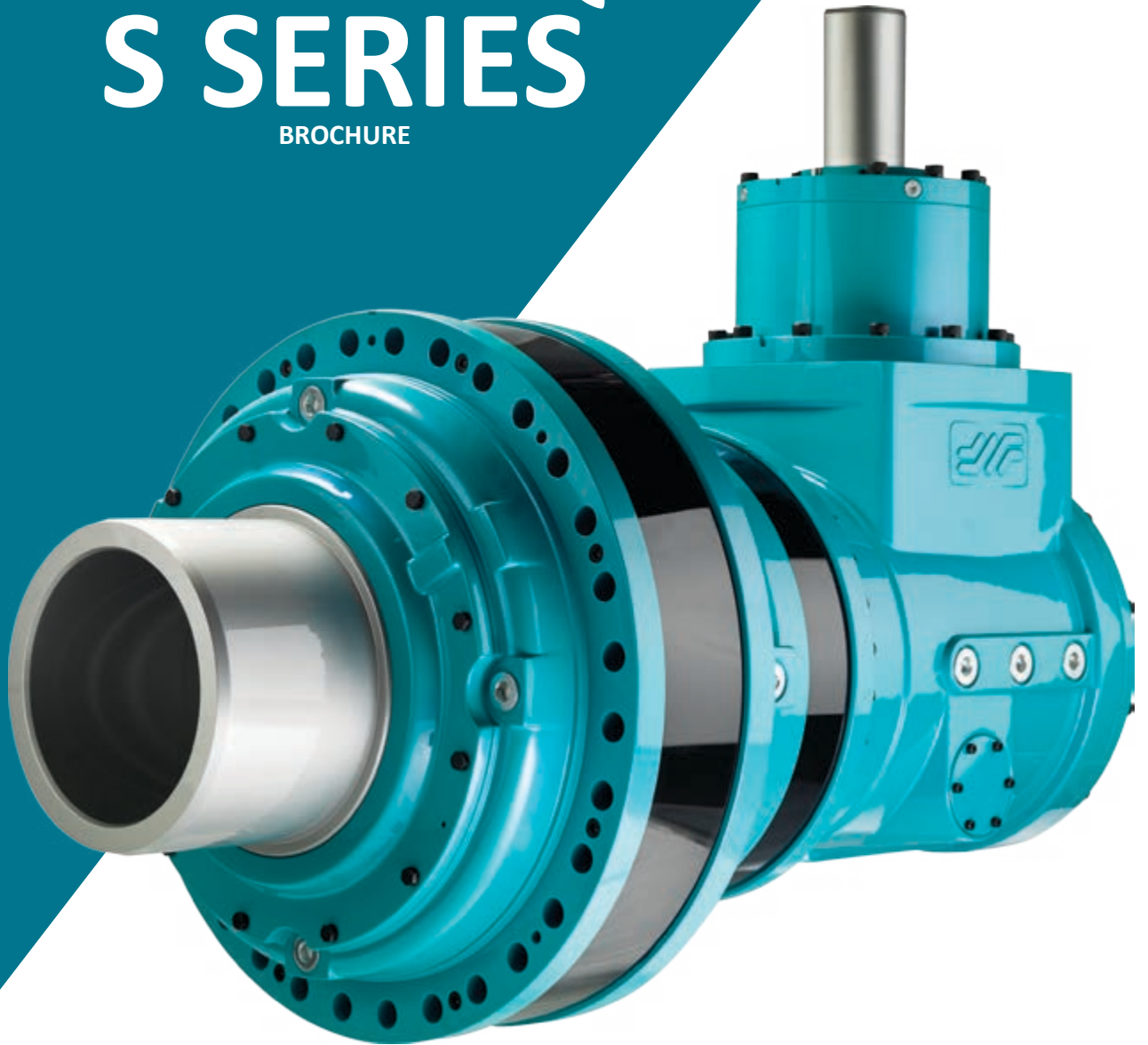

HISTORY

TECHNICAL FEATURES

APPLICATIONS OVERVIEW

BREVINI WORLD

brevini





Brevini: a history spanning 55 years

Brevini, with its power transmission division, is among the world's top five manufacturers in the sector of mechanical transmissions and gear drives, thanks to growing market shares in industrial applications (steel industry, plastics production, materials handling) and in innovative systems such as wind turbines, waste recycling plants, and energy production. Brevini is a major player also in the mining sector and in marine technologies. Established in 1960 by the brothers Renato, Luciano and Corrado, Brevini was the first Italian company to manufacture planetary gearboxes. The acquisition of PIV Drives GmbH in the 2002 has widened the portfolio with helical and bevel-helical products.

Many ingredients can change overtime to make a recipe more and more tasty, but some others need to stay. For Brevini, those are passion for products and people. The evolution of the core technologies and the related know-how spread around the world have had a key role in transforming in few decades an idea in a global multinational manufacturing and selling more than 150.000 gearboxes and 1 million hydraulic components per year. Moreover, the 2 divisions together are able to provide fully integrated solutions.

Brevini has enlarged its business scope to hydraulic components since the 70s.

The fluid power division has been established by the merge of companies from the fluid power sector with over forty years of experience. It is a main hub for made-in-Italy businesses in the mechatronics sector which includes, besides Brevini Fluid Power in Reggio Emilia, OT Oil Technology in Parma, as well as BPE Electronics in Novellara and VPS Brevini in Bologna.



Last but not least customer proximity comes. The closeness to the customer, in the double meaning of geography and deep understanding of dilemmas and needs, has always been a leitmotif in our values.

The coverage is ensured by a footprint of 40 subsidiaries, a strong distributors network and production plants in 4 continents.

Brevini in the heavy duty industrial

High torque S Series range

The industrial sector has been a pillar for Brevini starting from the '60s. Along the years, the know-how on products and applications and the capability to understand customers' need translating it into the best solution, have created hundreds of histories of success, especially in Heavy Duty and Marine sectors.

This clear win-win approach and a mutual trust are the base of the relationship with key global operators. The support all over the world is ensured by the wide global network of subsidiaries, without any doubt a key strength of the company: a joint effort by headquarters and local organizations never leaves the customer alone.

Brevini High Torque S series is the best solution for all applications requiring high torque with minimum dimensions. This planetary solution offers a substantial improvement in terms of space and weight with a torque range from 500kNm to 2000kNm.



The High Torque S series is also available as High Power version or NEW large bevel stages: a solution that is even more efficient, quieter and more compact. An example of how Brevini's product range has evolved according to the industry trends.



Talking about project management, once the need is clear, the feasibility study of the solution done and the order assigned, a dedicated team, with specific and skilled resources, takes in charge the development, acting as "a company into the company". The implementation of all the activities within a limited and focused number of people, as well as the collection and care of all the other relevant materials (documentation, certifications, training, presentations etc), ensures that all the phases/activities are properly planned and always kept under control.



Technical features

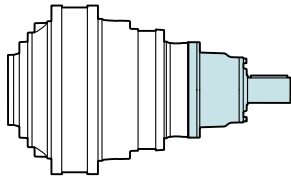

SL_				
	T_n [kNm]	T_{2MAX} [kNm]	Ratio (from-to)	Weight (kg)
SL50002	530	1100	18 - 30	2700
SL50003			75 - 180	2900
SL50004			300 - 1300	2900
SL50005			1300 - 8000	2900
SL75002	735	1800	20 - 35	4200
SL75003			85 - 180	4500
SL75004			340 - 1300	4600
SL75005			1350 - 7800	4700
SL100003	1035	2600	85 - 180	6900
SL100004			350 - 1300	6950
SL100005			1400 - 6500	7000
SL150003	1500	3750	90 - 150	9500
SL150004			370 - 1000	9700
SL150005			1500 - 6600	9800
SL200003	2170	5400	100 - 170	14300
SL200004			420 - 1000	14500
SL200005			1700 - 6000	15150
SL200006			4500 - 8000	15200

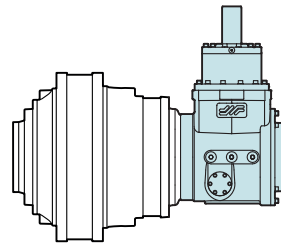

SC_				
	T_n [kNm]	T_{2MAX} [kNm]	Ratio (from-to)	Weight (kg)
SC50003	530	1100	36 - 128	3000
SL50004			152 - 769	3100
SC75003	735	1800	41 - 146	5400
SC75004			171 - 747	6500
SC100004	1035	2600	171 - 609	7800
SC100005			717 - 4486	7200
SC150004	1500	3750	178 - 763	10400
SC150005			746 - 3775	10220
SC200004	2170	5400	201 - 720	16400
SC200005			842 - 4321	15700

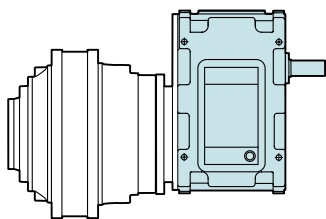

SL_PB_				
	T_n [kNm]	T_{2MAX} [kNm]	Ratio (from-to)	Weight (kg)
SL2PB50031	530	1100	30 - 75	3600
SL3PB50020			180 - 300	3050
SL2PB75031	735	1800	35 - 85	5450
SL3PB75025			180 - 340	5250
SL3PB100031			180 - 350	8100
SL3PB150031	1500	3750	150 - 370	10550
SL4PB150020			1000 - 1500	10050
SL3PB200031	2170	5400	170 - 420	15400
SL4PB200025			1000 - 1700	14650

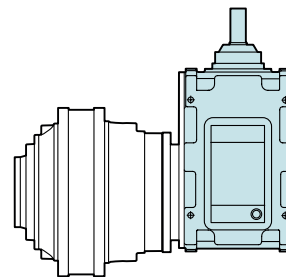

SL_PLB_				
	T_n [kNm]	T_{2MAX} [kNm]	Ratio (from-to)	Weight (kg)
SL2PLB50031	530	1100	60 - 225	3800
SL3PLB50020			225 - 750	3100
SL2PLB75031	735	1800	60 - 250	6600
SL3PLB75025			250 - 1000	5500
SL4PLB75016			1000 - 8000	5000
SL3PLB100031	1035	2600	250 - 1000	8300
SL4PLB100020			1000 - 8000	7500
SL3PLB150031	1500	3750	270 - 1100	10750
SL4PLB150020			1100 - 8000	10100
SL3PLB200031	2170	5400	300 - 1250	15700
SL4PLB200025			1250 - 8000	15400

Flange Mounted Gearbox - FE

Female splined output shaft

This classic solution, female splined shaft, it is designed to transmit torque only. External radial or axial loads are not admitted

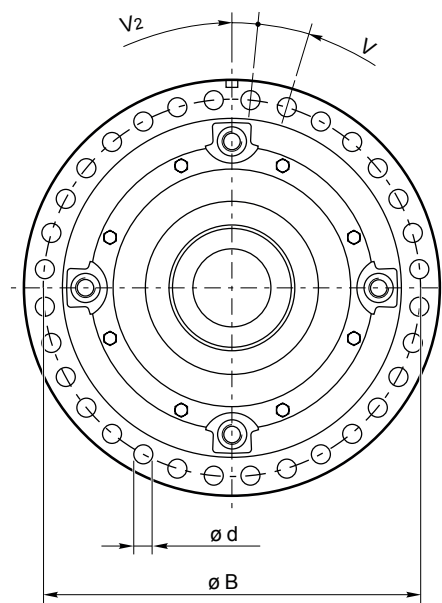
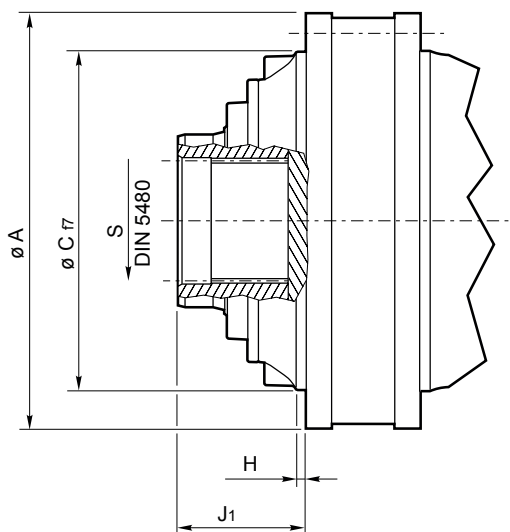

	A	B	C	d	H	J1	S	V	V2
S5000	980	900	810	39	14	338	N340x8x30x41x9H	n°32x11.25°	5.625°
S75000	1160	1070	970	40	20	413	N400x8x30x48x9H	n°40x9°	4.5°
S10000	1345	1230	1130	46	20	447	N460x8x30x56x9H	n°36x10°	5°
S15000	1500	1380	1260	50	25	490	N500x8x30x61x9H	n°40x9°	4.5°
S20000	1730	1600	1455	58	30	580	N600x10x30x58x9H	n°36x10°	5°

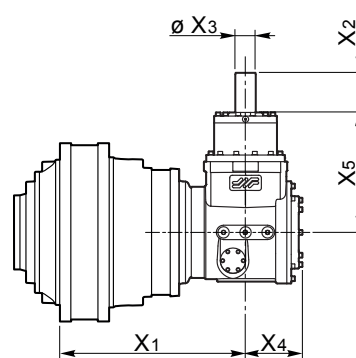
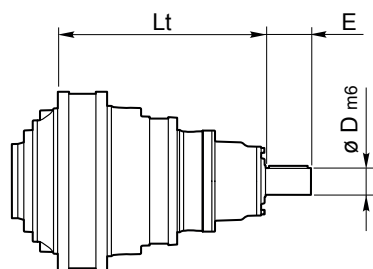

SL_				
	Input	Lt	E	D
SL50002	IS1800	1229	500	150
SL50003	IS600	1264	210	110
SL50004	ISL250	1320	130	90
SL50005	S46C1	1493	105	65
SL75002*	FGC30	913	-	-
SL75003	IS850	1456	210	110
SL75004	ISL300	1396	130	90
SL75005	ISL150	1634	130	90
SL100003	IS1200	1689	484	130
SL100004	ISL300	1617	130	90
SL100005	ISL150	1775	130	90
SL150003	IS1800	1937	500	150
SL150004	IS600	1957	210	110
SL150005	ISL250	2013	130	90
SL200003*	FGC30	1728	-	-
SL200004	IS850	2271	210	110
SL200005	ISL300	2291	130	90
SL200006	ISL150	2449	130	90

SC_					
	X1	X2	X3	X4	X5
SC50003	1017	210	110	330	675
SC50004	1235	170	80	277	554
SC75003	1154.5	250	130	442	765
SC75004	1359	170	80	277	554
SC100004	1544	210	110	330	675
SC100005	1652	170	80	213	420
SC150004	1708	210	110	330	675
SC150005	1928	170	80	277	554
SC200004	1970	250	130	442	765
SC200005	2173	170	80	277	554

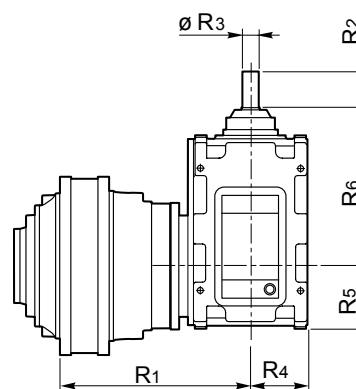
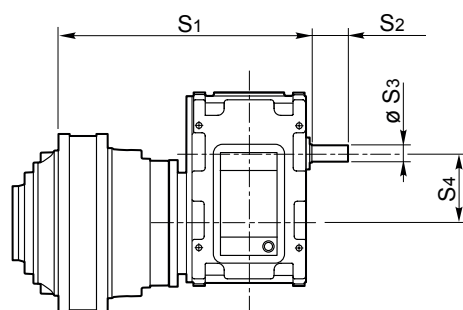

SL_PB_				
	S1	S2	S3	S4
SL2PB50031	1353	250	130	302
SL3PB50020	1412	170	80	201
SL2PB75031	1)	1)	1)	1)
SL3PB75025	1623	215	100	247
SL3PB100031	1878	250	130	302
SL3PB150031	2046	250	130	302
SL4PB150020	2105	170	80	201
SL3PB200031	2420	250	130	302
SL4PB200025	2438	215	100	247

SL_PLB_						
	R1	R2	R3	R4	R5	R6
SL2PLB50031	1021	180	85	347.5	323	884
SL3PLB50020	1186	145	60	205	233	578
SL2PLB75031	1273	180	85	347.5	323	884
SL3PLB75025	1343	160	75	219	277	731
SL4PLB75016	1517.5	120	50	174	201	491
SL3PLB100031	1546	180	85	347.5	323	884
SL4PLB100020	1681.5	145	60	205	233	578
SL3PLB150031	1714	180	85	347.5	323	884
SL4PLB150020	1879	145	60	205	233	578
SL3PLB200031	2156	180	85	347.5	323	884
SL4PLB200025	2158	160	75	219	277	731

Other solution available on request. Please contact The Brevini Technical support for further information.
 * Gearboxes with FGC are input open configuration.

Shaft Mounted Gearbox - FAR

Female splined output shaft

Cantilever solution via splined shaft or drive flange.

Easy to assemble and disassemble.

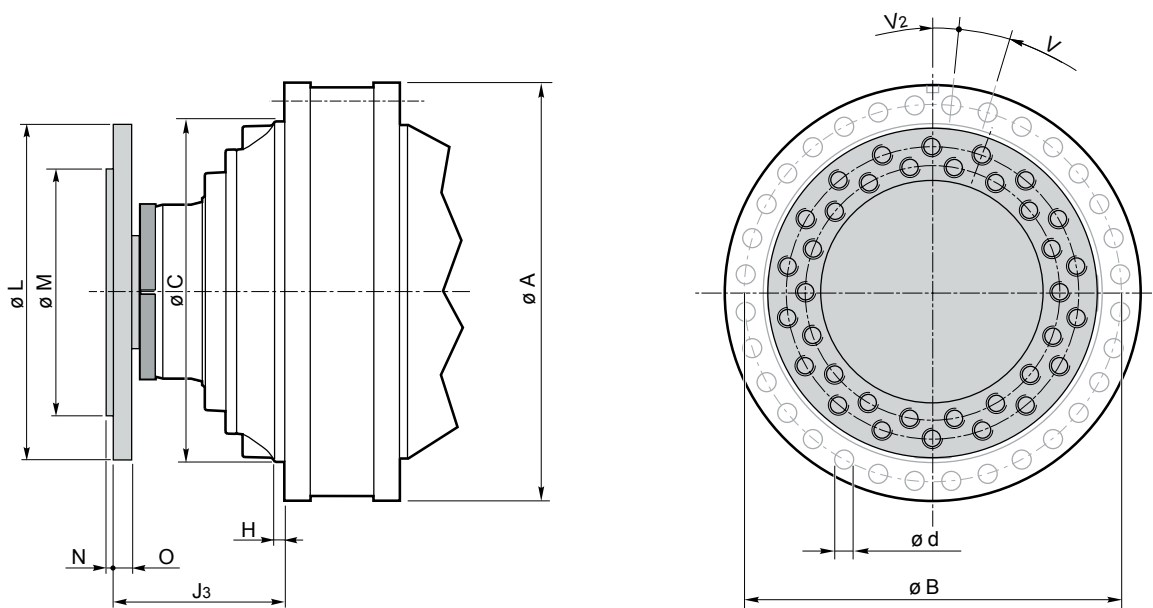

	A	B	C	d	H	J3	V	V2	L	M	N	O
S5000	980	900	810	39	14	425	n°32x11.25°	5.625°	800	620	10	50
S75000	1160	1070	970	40	20	530	n°40x9°	4.5°	960	650	10	60
S10000	1345	1230	1130	46	20	630	n°36x10°	5°	1100	740	15	60
S15000	1500	1380	1260	50	25	710	n°40x9°	4.5°	1240	810	15	70
S20000	1730	1600	1455	58	30	800	n°36x10°	5°	1445	1200	15	85

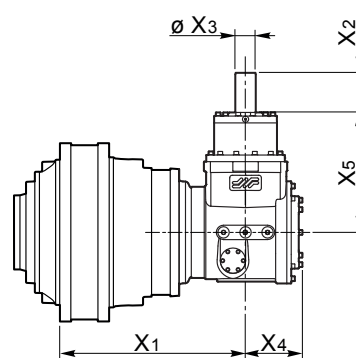
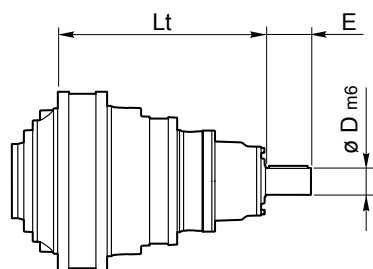

SL_				
	Input	Lt	E	D
SL50002	IS1800	1229	500	150
SL50003	IS600	1264	210	110
SL50004	ISL250	1320	130	90
SL50005	S46C1	1493	105	65
SL75002*	FGC30	913	-	-
SL75003	IS850	1456	210	110
SL75004	ISL300	1396	130	90
SL75005	ISL150	1634	130	90
SL100003	IS1200	1689	484	130
SL100004	ISL300	1617	130	90
SL100005	ISL150	1775	130	90
SL150003	IS1800	1937	500	150
SL150004	IS600	1957	210	110
SL150005	ISL250	2013	130	90
SL200003*	FGC30	1728	-	-
SL200004	IS850	2271	210	110
SL200005	ISL300	2291	130	90
SL200006	ISL150	2449	130	90

SC_					
	X1	X2	X3	X4	X5
SC50003	1017	210	110	330	675
SC50004	1235	170	80	277	554
SC75003	1154.5	250	130	442	765
SC75004	1359	170	80	277	554
SC100004	1544	210	110	330	675
SC100005	1652	170	80	213	420
SC150004	1708	210	110	330	675
SC150005	1928	170	80	277	554
SC200004	1970	250	130	442	765
SC200005	2173	170	80	277	554

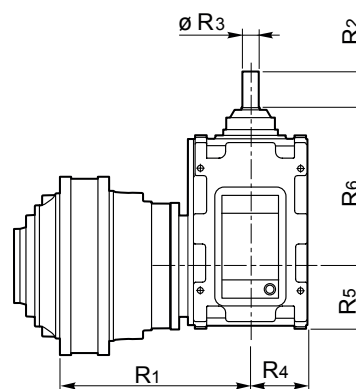
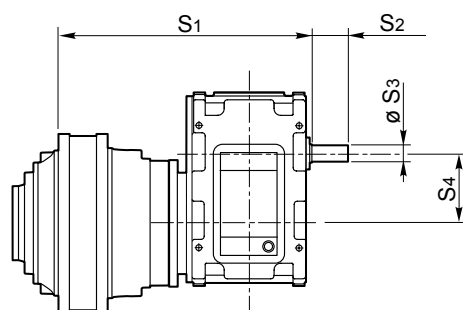

SL_PB_				
	S1	S2	S3	S4
SL2PB50031	1353	250	130	302
SL3PB50020	1412	170	80	201
SL2PB75031	1)	1)	1)	1)
SL3PB75025	1623	215	100	247
SL3PB100031	1878	250	130	302
SL3PB150031	2046	250	130	302
SL4PB150020	2105	170	80	201
SL3PB200031	2420	250	130	302
SL4PB200025	2438	215	100	247

SL_PLB_						
	R1	R2	R3	R4	R5	R6
SL2PLB50031	1021	180	85	347.5	323	884
SL3PLB50020	1186	145	60	205	233	578
SL2PLB75031	1273	180	85	347.5	323	884
SL3PLB75025	1343	160	75	219	277	731
SL4PLB75016	1517.5	120	50	174	201	491
SL3PLB100031	1546	180	85	347.5	323	884
SL4PLB100020	1681.5	145	60	205	233	578
SL3PLB150031	1714	180	85	347.5	323	884
SL4PLB150020	1879	145	60	205	233	578
SL3PLB200031	2156	180	85	347.5	323	884
SL4PLB200025	2158	160	75	219	277	731

Other solution available on request. Please contact The Brevini Technical support for further information.
 * Gearboxes with FGC are input open configuration.

Shaft Mounted Gearbox - FS

Female output shaft

Keyless direct mounting via shrink disk

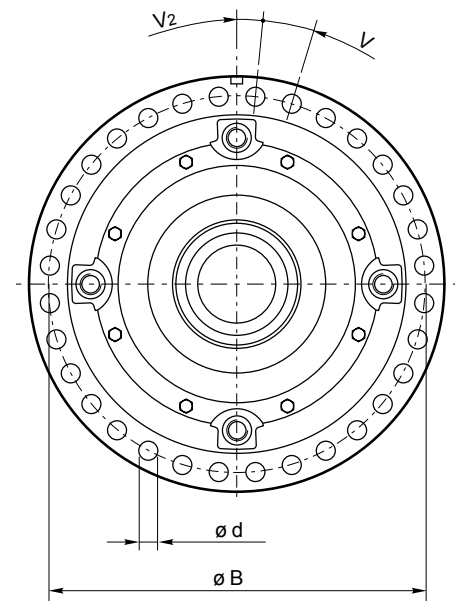
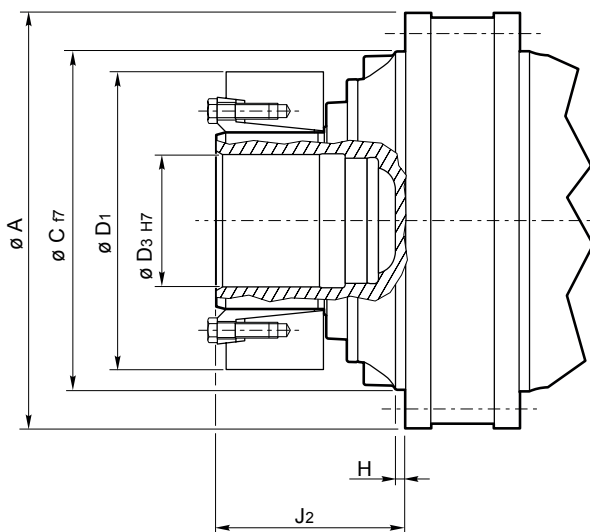

	T_n [kNm]	T_{jn} [kNm]	Coupling Type
S5000	530	1163	3208-420x680
S75000	735	1632	3009-500x850
S10000	1035	2327	3009-560x940
S15000	1500	3226	3009-620x970
S20000	2170	5799	3009-750x1230

T_n = Gear unit nominal torque
 T_{jn} = Joint nominal torque

	A	B	C	d	D1	D3	H	J2	V	V2
S5000	980	900	810	39	680	340	14	438	n°32x11.25°	5.625°
S75000	1160	1070	970	40	850	400	20	530	n°40x9°	4.5°
S10000	1345	1230	1130	46	940	460	20	630	n°36x10°	5°
S15000	1500	1380	1260	50	970	510	25	710	n°40x9°	4.5°
S20000	1730	1600	1455	58	1230	600	30	800	n°36x10°	5°

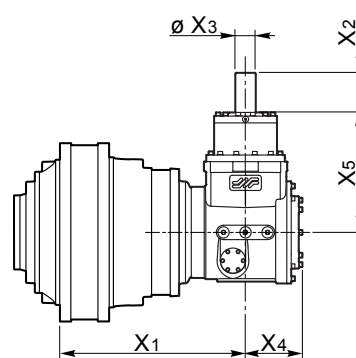
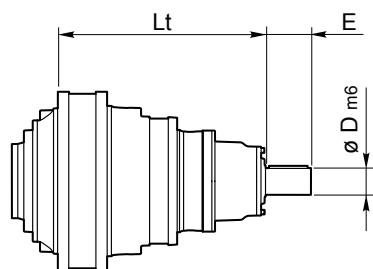

SL_				
	Input	Lt	E	D
SL50002	IS1800	1229	500	150
SL50003	IS600	1264	210	110
SL50004	ISL250	1320	130	90
SL50005	S46C1	1493	105	65
SL75002*	FGC30	913	-	-
SL75003	IS850	1456	210	110
SL75004	ISL300	1396	130	90
SL75005	ISL150	1634	130	90
SL100003	IS1200	1689	484	130
SL100004	ISL300	1617	130	90
SL100005	ISL150	1775	130	90
SL150003	IS1800	1937	500	150
SL150004	IS600	1957	210	110
SL150005	ISL250	2013	130	90
SL200003*	FGC30	1728	-	-
SL200004	IS850	2271	210	110
SL200005	ISL300	2291	130	90
SL200006	ISL150	2449	130	90

SC_					
	X1	X2	X3	X4	X5
SC50003	1017	210	110	330	675
SC50004	1235	170	80	277	554
SC75003	1154.5	250	130	442	765
SC75004	1359	170	80	277	554
SC100004	1544	210	110	330	675
SC100005	1652	170	80	213	420
SC150004	1708	210	110	330	675
SC150005	1928	170	80	277	554
SC200004	1970	250	130	442	765
SC200005	2173	170	80	277	554

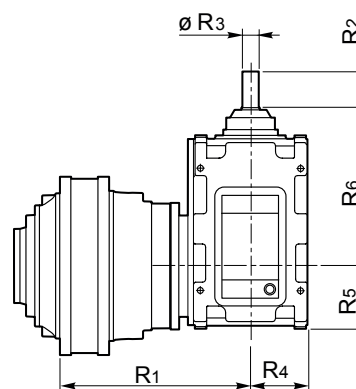
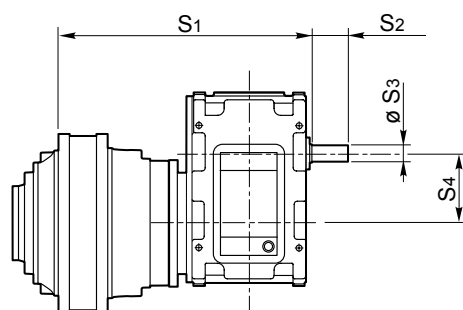

SL_PB_				
	S1	S2	S3	S4
SL2PB50031	1353	250	130	302
SL3PB50020	1412	170	80	201
SL2PB75031	1)	1)	1)	1)
SL3PB75025	1623	215	100	247
SL3PB100031	1878	250	130	302
SL3PB150031	2046	250	130	302
SL4PB150020	2105	170	80	201
SL3PB200031	2420	250	130	302
SL4PB200025	2438	215	100	247

SL_PLB_						
	R1	R2	R3	R4	R5	R6
SL2PLB50031	1021	180	85	347.5	323	884
SL3PLB50020	1186	145	60	205	233	578
SL2PLB75031	1273	180	85	347.5	323	884
SL3PLB75025	1343	160	75	219	277	731
SL4PLB75016	1517.5	120	50	174	201	491
SL3PLB100031	1546	180	85	347.5	323	884
SL4PLB100020	1681.5	145	60	205	233	578
SL3PLB150031	1714	180	85	347.5	323	884
SL4PLB150020	1879	145	60	205	233	578
SL3PLB200031	2156	180	85	347.5	323	884
SL4PLB200025	2158	160	75	219	277	731

Other solution available on request. Please contact The Brevini Technical support for further information.
 * Gearboxes with FGC are input open configuration.

Mounting position & oil quantities

SL_	Oil		
	V5	V6	B3
SL50002	128	128	65
SL50003	120	120	61
SL50004	139	139	71
SL50005	159	159	81
SL75002*	-	-	-
SL75003	215	215	109
SL75004	213	213	108
SL75005	213	213	108
SL100003	318	318	161
SL100004	265	265	135
SL100005	266	266	136
SL150003	394	394	201
SL150004	401	401	205
SL150005	411	411	210
SL200003*	-	-	-
SL200004	667	667	340
SL200005	647	647	330
SL200006	656	656	335

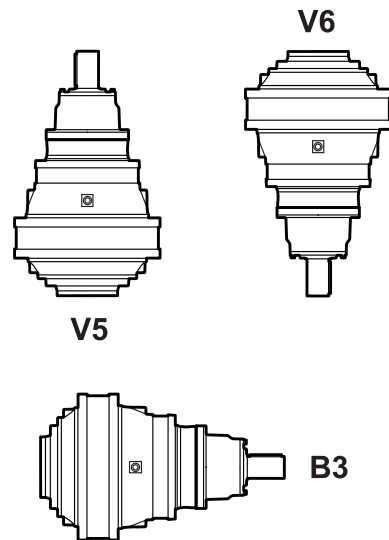

SC_	Oil					
	V5B	V6B	B3A	B3B	B3C	B3D
SC50003	167	167	85	167	85	167
SC50004	167	167	85	167	85	167
SC75003	294	294	150	294	150	294
SC75004	255	255	130	255	130	255
SC100004	343	343	175	343	175	343
SC100005	304	304	155	304	155	304
SC150004	470	470	240	470	240	470
SC150005	451	451	230	451	230	451
SC200004	731	731	373	731	373	731
SC200005	696	696	355	696	355	696

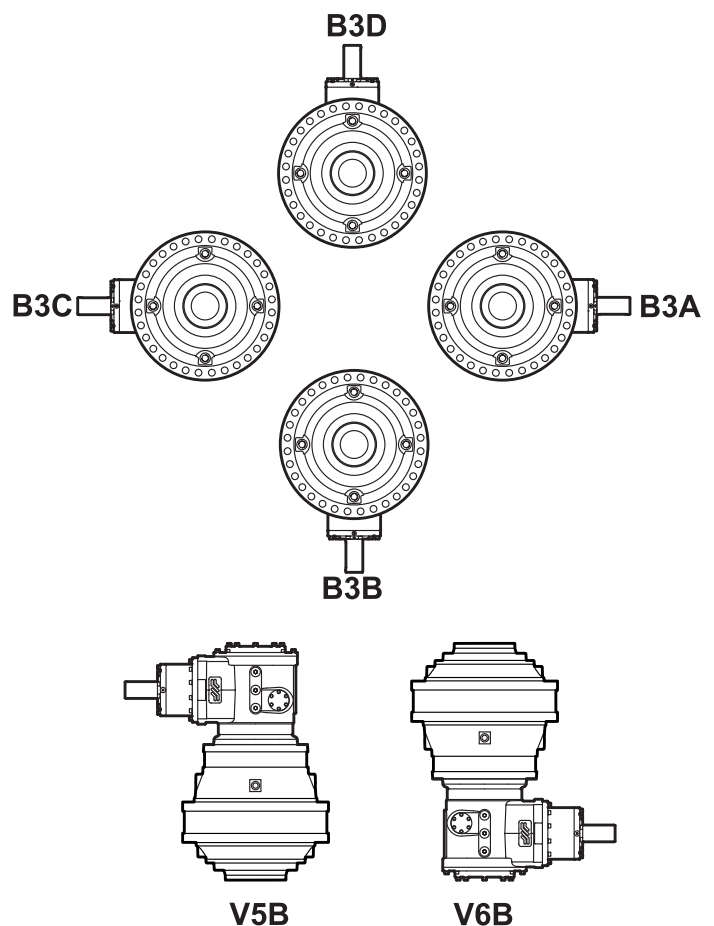

* Gearboxes with FGC are input open configuration, oil quantity can not be estimated.

SL_PB_						
	Oil					
	V5B	V6B	B3A	B3B	B3C	B3D
SL2PB50031	359	359	183	359	183	359
SL3PB50020	194	194	99	194	99	194
SL2PB75031	365	365	186	365	186	365
SL3PB75025	351	351	179	351	179	351
SL3PB100031	545	545	278	545	278	545
SL3PB150031	623	623	318	623	318	623
SL4PB150020	472	472	241	472	241	472
SL3PB200031	876	876	447	876	447	876
SL4PB200025	757	757	386	757	386	757

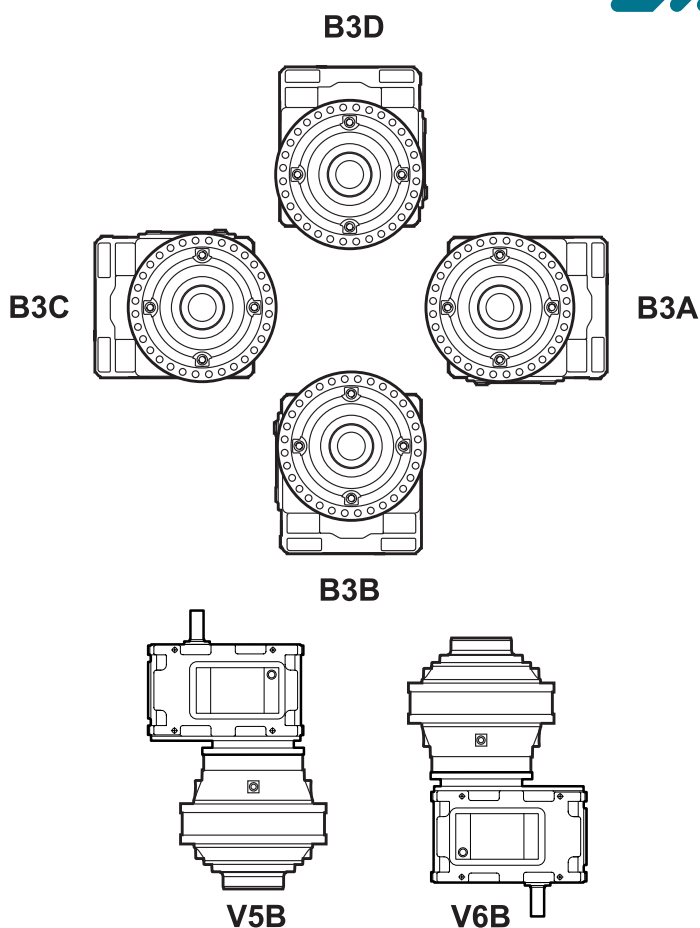

SL_PLB_						
	Oil					
	V5B	V6B	B3A	B3B	B3C	B3D
SL2PLB50031	363	363	185	363	185	363
SL3PLB50020	198	198	101	198	101	198
SL2PLB75031	369	369	188	369	188	369
SL3PLB75025	355	355	181	355	181	355
SL4PLB75016	216	216	110	216	110	216
SL3PLB100031	551	551	281	551	281	551
SL4PLB100020	343	343	175	343	175	343
SL3PLB150031	629	629	321	629	321	629
SL4PLB150020	480	480	245	480	245	480
SL3PLB200031	882	882	450	882	450	882
SL4PLB200025	764	764	390	764	390	764

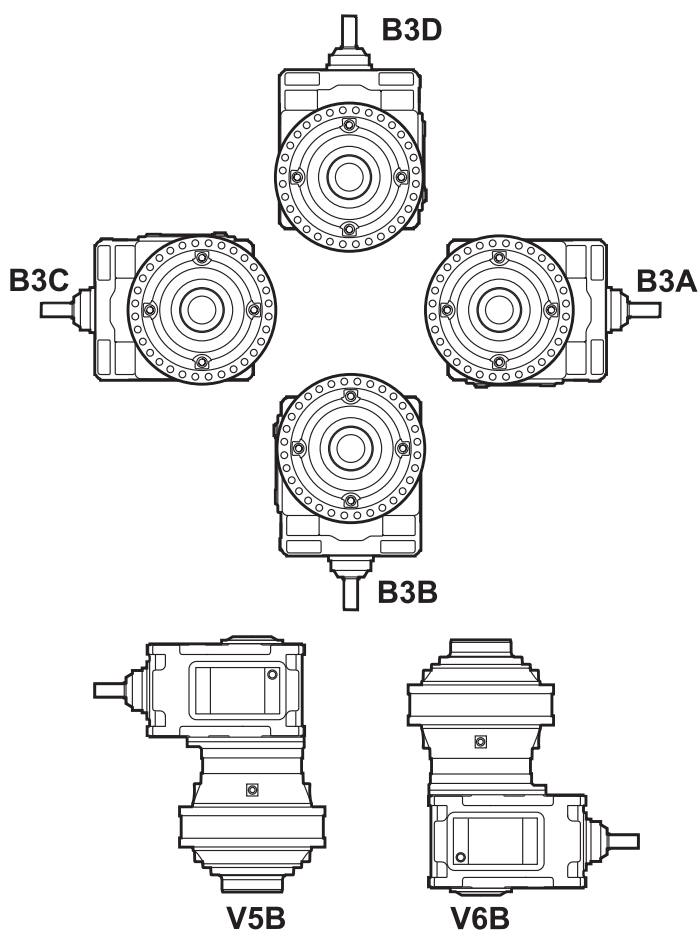

Accessories

Auxiliary cooling devices

When necessary, due to tough conditions, Brevini gearbox thermal capacity can be upgrade with dedicated devices or the oil/housing can be heated up in case of very low temperature.

Different solutions for any kind of need:

- **Cooling fan fitted to the HSS with proper cover**
- **Cooling coils**
- **Integrated cooling units (air/oil or water/oil)**
- **Standalone cooling units (air/oil or water/oil)**
- **Electrical heating elements**

Additional devices like PT100 can be supplied as well for better monitoring.

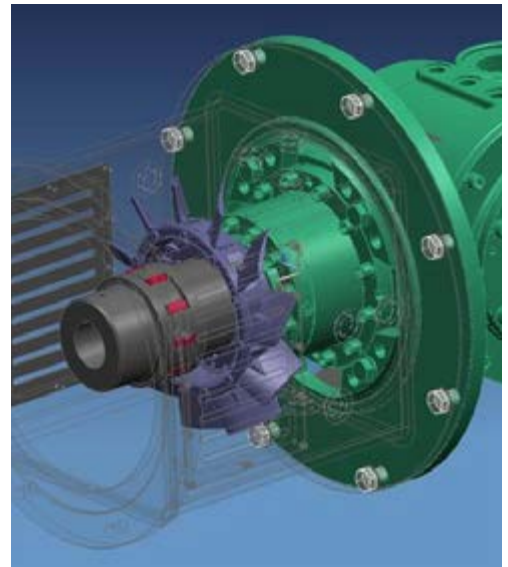

Forced lubrication and filtering systems

In demanding applications, over the standard splash lubrication, a forced lubrication or filtering system can be supplied. This will grant proper gears and bearings lubrication or will help to maintain a good level of cleanness of the lubricating oil.

For all this cases, Brevini is capable to provide dedicated solution as:

- **Forced lubrication systems with independently powered pumps**
- **Forced lubrication systems with mechanically driven pumps**

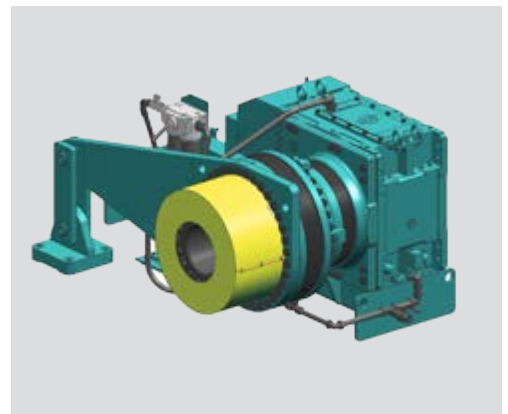

Torque arm

For shaft mounted applications Brevini can supply a wide range of standard torque arms for use with combination of FS or FAR gearboxes.

For special and specific customized power transmission solution Brevini can offer further devices:

- **Base plates**
- **Foot pedestals**
- **Brakes:**
 - hydraulic or electromagnetic
 - drum, shoe or disk brake
- **Fluid coupling**
- **Plug-in male shaft or drive flange**
- **Electric or hydraulic motors**
- **Oil level devices**



Applications overview



- A. SL100003/FS - Mexico
- B. SL2PLB100045/MP1 - Brazil
- C. SL75004/FS - Mozambique
- D. SL2PLB50031/FAR - India
- E. SL150005/FS - France





F.



F.

F. SL150005/FS - France



G.

G. SL50003/FS - Thailand
H. SL3PLB50020/FAR - Mexico
I. SL2PLB50031/MP1 - Brazil
L. SL2PLB50031/FAR - India
M. SC50003/FE - Switzerland



H.



I.



L.



M.

Brevini Worldwide - Manufacturing



Brevini HeadQuarters

Via Luciano Brevini 1/A - 42124 Reggio Emilia
(Italy)

Tel +39 0522 9281

Fax +39 0522 928300

Mail brevini@brevini.com



Brevini Fluid Power

Via Moscova, 6 - 42124 Reggio Emilia
(Italy)

Tel +39 0522 270 711

Fax +39 0522 270 660

Mail info@brevinifluidpower.com



Brevini Posiplan S.R.L.U.

Zona industriale "Il Castello" - Via Perarolo, 504/2
Badia Polesine (RO) (Italy)

Tel +39 0425 594 162

Fax +39 0425 585 821

Mail fabio.lacerti@brevini.com



Brevini Latino Americana

Via Prof. Jurandyr Paixao, 1900 - Jd. Campo Belo,
13481-149 - Limeira - Sao Paulo - Brazil (Brazil)

Tel 0055 19 3446 8600

Fax 0055 19 3446 8601

Mail brevini@brevini.com.br



PIV Drives GmbH

Justus-von-Liebig-Straße 3 - 61352 Bad Homburg
(Germany)

Tel +49 (0) 6172/102 0

Fax +49 (0) 6172/102 380

Mail info-piv@brevini.com



Brevini China Shanghai Gearboxes

Rm.1504, Block 1, Sandhill Plaza, No.2290
Zuchongzhi Rd, Shanghai 200120 (China)

Tel 0086 21 68880255

Fax 0086 21 58780944

Mail info@brevinifluidpowersh.com



Manufacturing Plant



Competence Center Winches



Engineering & Service Center



Sales & Assembly Subsidiary



Sales Regional Office



Authorized Distributor



Plants and local presence

Global Expertise

The global **network** of Brevini production sites is composed by eleven plants, with the headquarters and main facilities in Italy (Reggio Emilia), the German company PIV, two sites in China (Brevini Power Transmission and Brevini Fluid Power in Yancheng), the American site in Yorktown and the one in Brazil, in Limeira.

The worldwide direct presence is our strength, with “centers of expertise”, capable to ensure engineering know-how, product customization, widespread sales support and after-sales services.

